

Live ODS Video

Robert Konrad



SCI | STANFORD
COMPUTATIONAL
IMAGING LAB



Live ODS Video

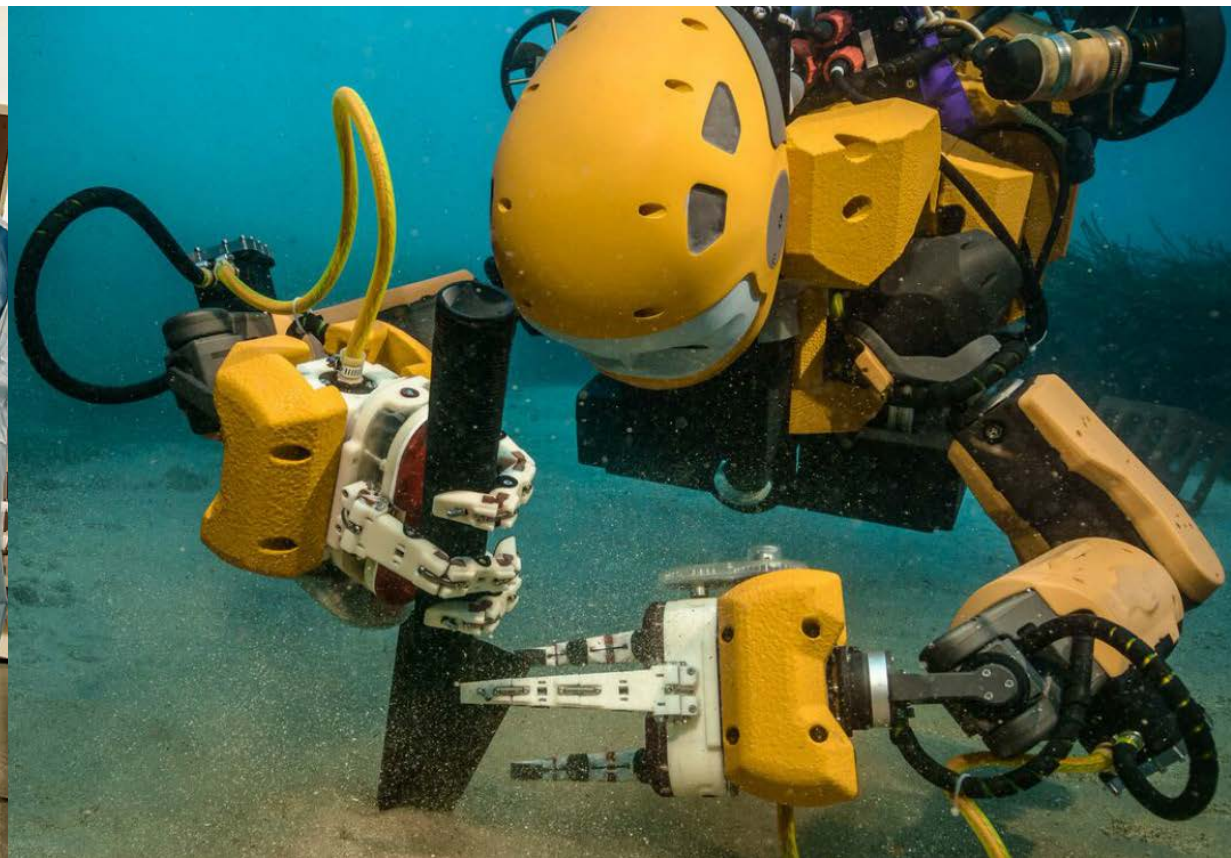

(Some) Stereo VR Cameras

Z-Cam V1 Pro



Kandao Obsidian R



Insta360 Titan



Facebook Surround 360



Facebook Manifold



Yi Halo



Omnidirectional Stereo (ODS)

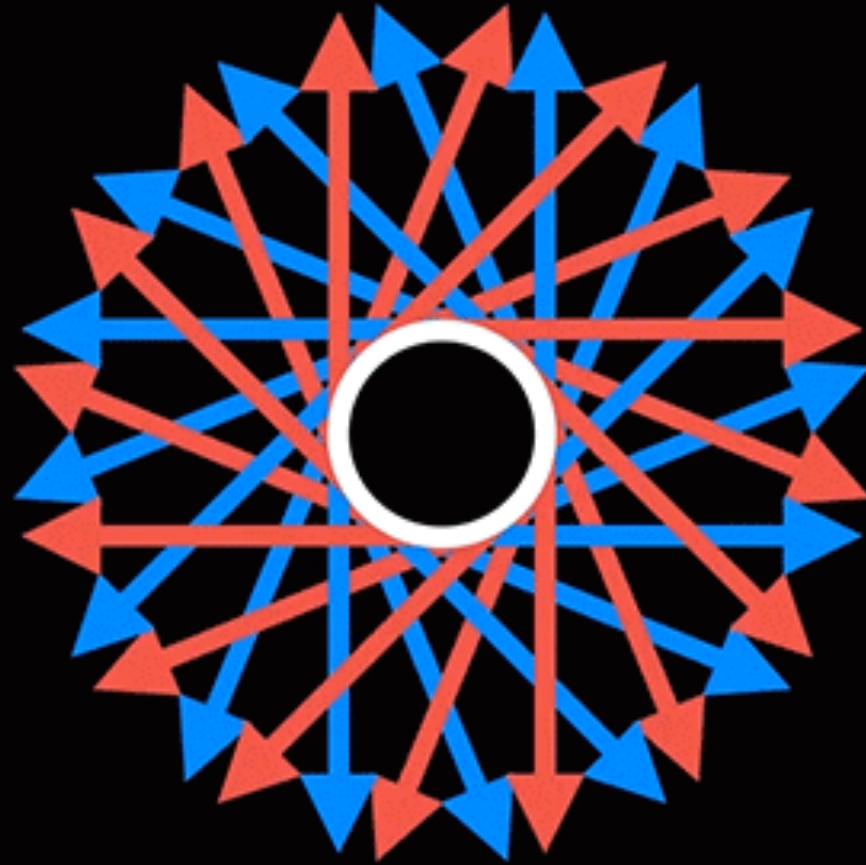

Ishiguro et al. 1990

Peleg et al. 2001

Getting these tangential rays is non-trivial from camera arrays!

[Anderson et. al, SIGGRAPH Asia 2016]

CAMERA 1



Challenges for optical flow

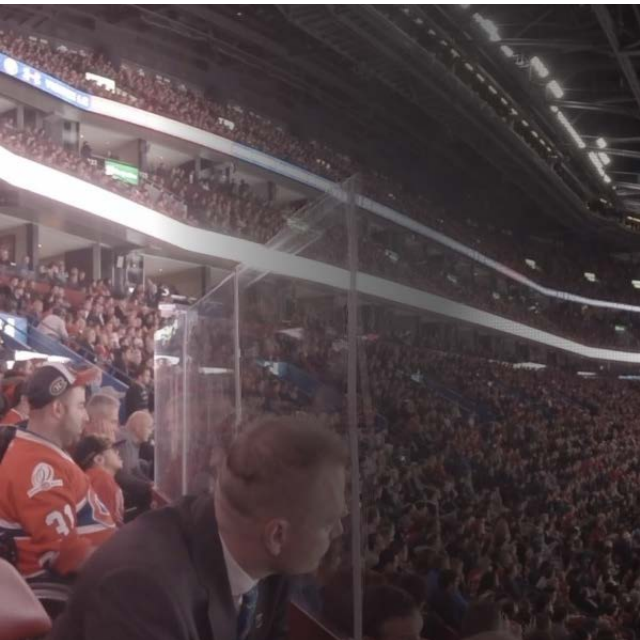

Transparency, reflections



Flow mismatches



Fine Structures



Too Close

INTERPOLATION

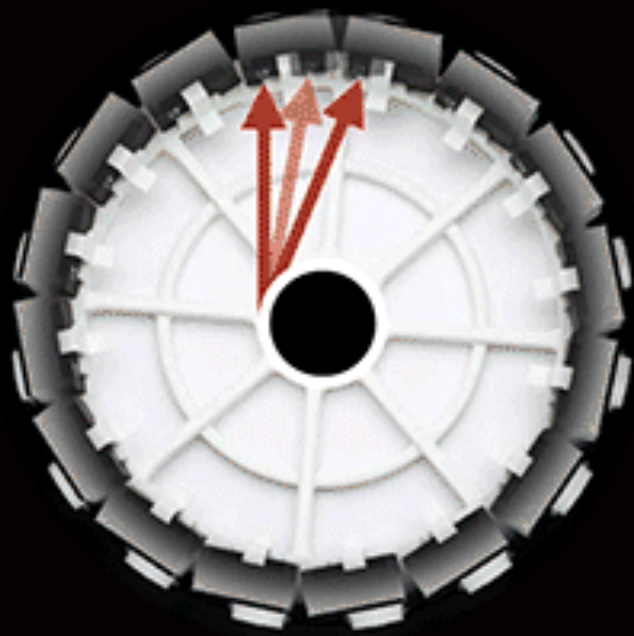

Per-Frame Flow



Temporally Consistent Flow

Google Jump – Computation Time Breakdown

60 sec / frame

(single machine)

Google Jump – Computation Time Breakdown

Video Length

1 hour

60 sec / frame

(single machine)

Total time to process

75 days

Google Jump – Computation Time Breakdown

Video Length

1 hour

60 sec / frame
→
(single machine)

Total time to process

75 days

1 hour

321 sec / frame
→
(parallelized on
1000 cores)

10 hours

Google Jump – Computation Time Breakdown

Video Length

Total time to process

1 hour

60 sec / frame
→
(single machine)

75 days

1 hour

321 sec / frame
→
(parallelized on
1000 cores)

10 hours

Operation	Time (sec.)
Flow computation	183
Compositing	54
Frame IO and rectification	40
Flow compression/decompression	38
Post processing/one off setup	6
Total	321

Google Jump – Computation Time Breakdown

Video Length

Total time to process

1 hour

60 sec / frame
→
(single machine)

75 days

1 hour

321 sec / frame
→
(parallelized on
1000 cores)

10 hours

Operation	Time (sec.)
Flow computation	183
Compositing	54
Frame IO and rectification	40
Flow compression/decompression	38
Post processing/one off setup	6
<hr/> Total	<hr/> 321

Google Jump – Computation Time Breakdown

Video Length

Total time to process

1 hour

60 sec / frame
→
(single machine)

75 days

1 hour

321 sec / frame
→
(parallelized on
1000 cores)

10 hours

Operation	Time (sec.)
Flow computation	183
Compositing	54
Frame IO and rectification	40
Flow compression/decompression	38
Post processing/one off setup	6
Total	321

What is real time?

processing time \leq capture rate

capture rate \neq display rate

Live Streaming Camera Arrays

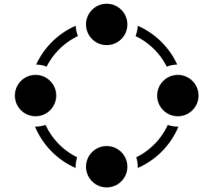

Single Shot ODS capture



Rotating ODS capture

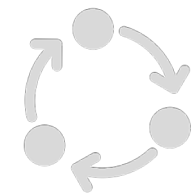

Live Streaming Camera Arrays



Kandao Obsidian R



Samsung Round



Z-Cam V1 Pro



LivePlanet



Insta360 Titan



Rely on calibration

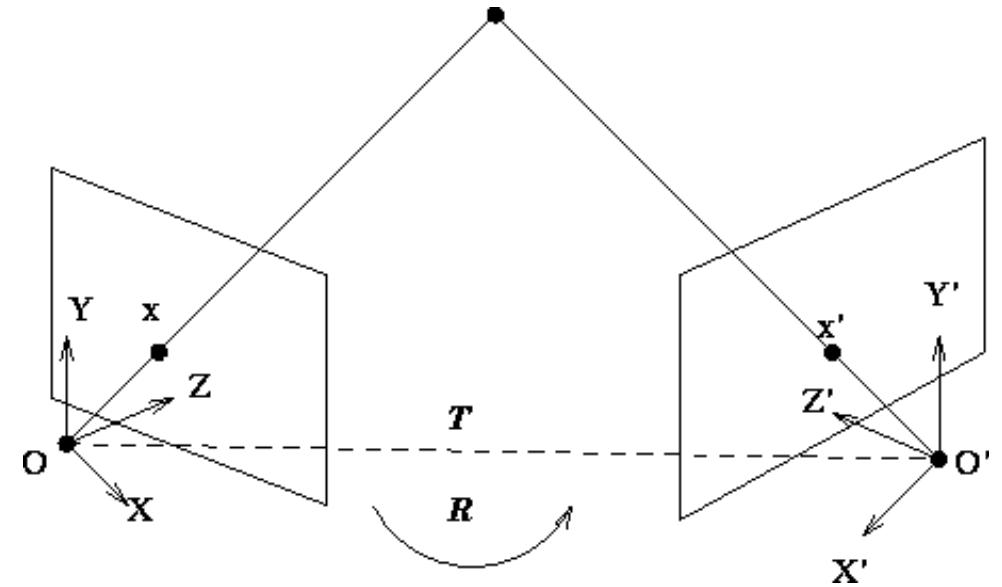
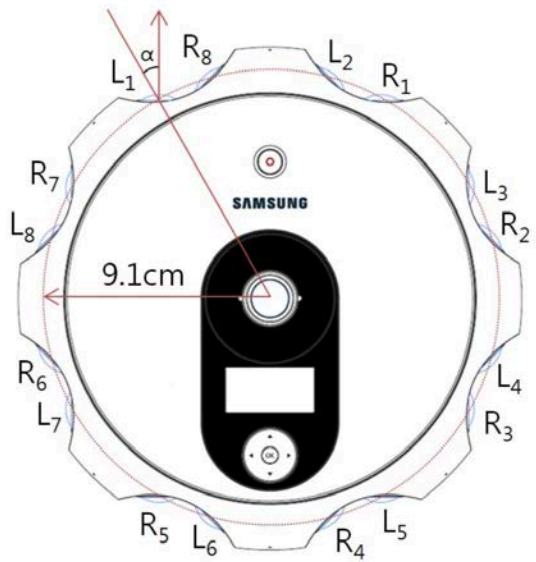

Rely on calibration

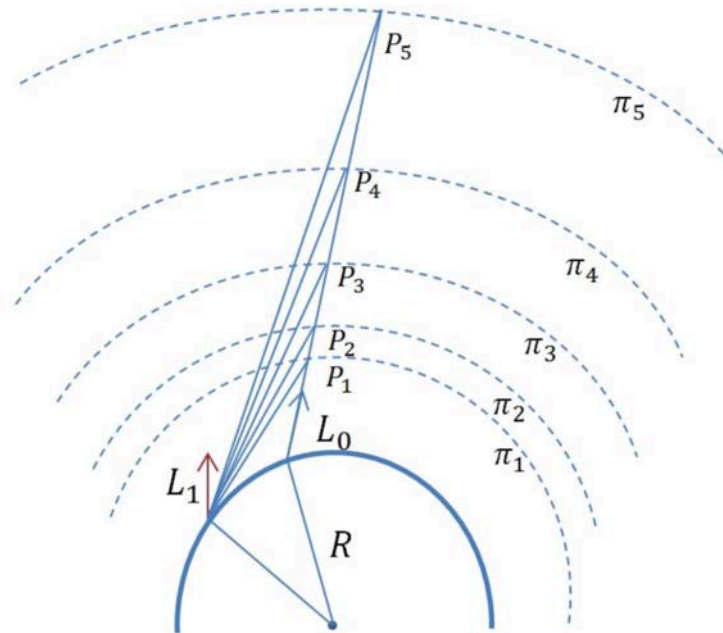
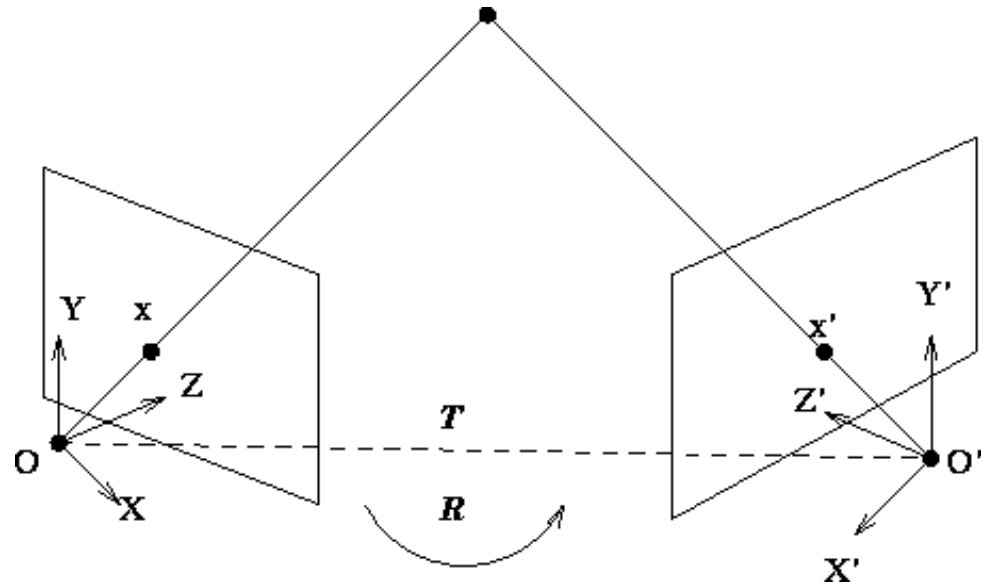
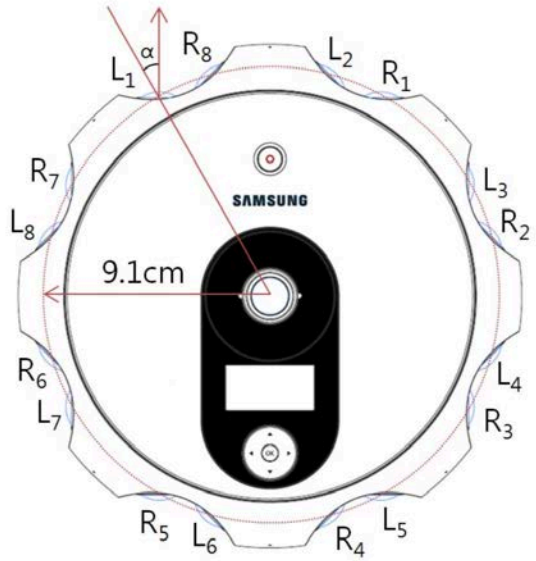

Rely on calibration

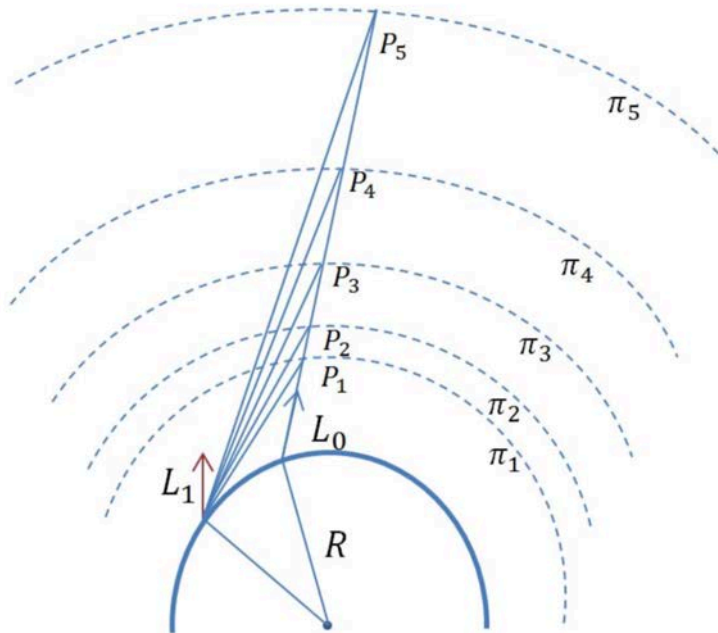
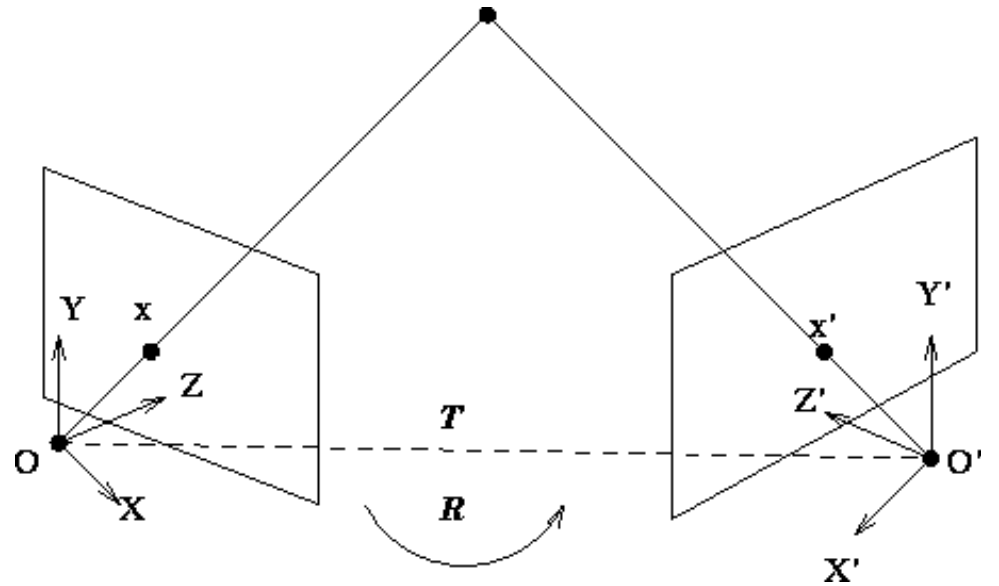
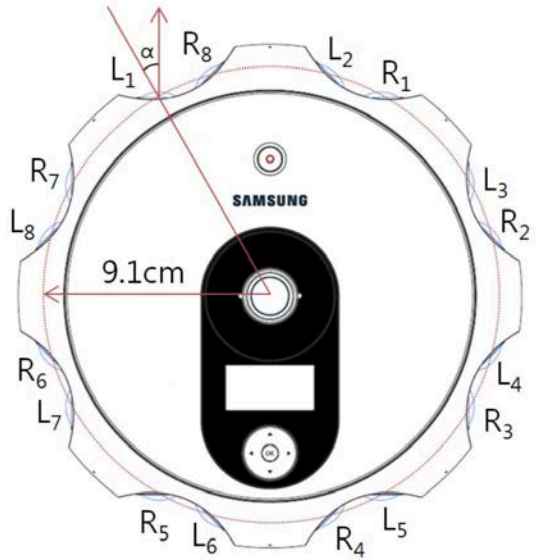

Don't compute 2D optical flow

Rely on calibration

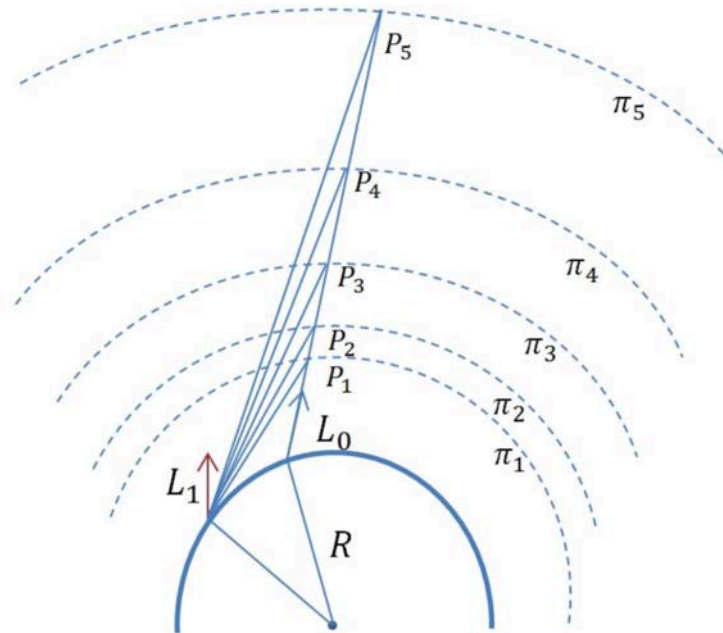
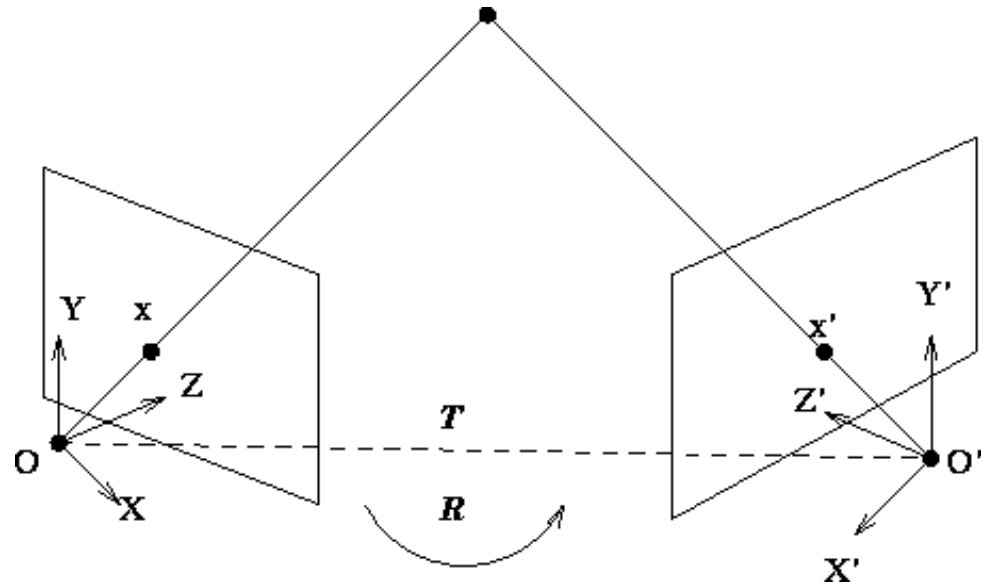
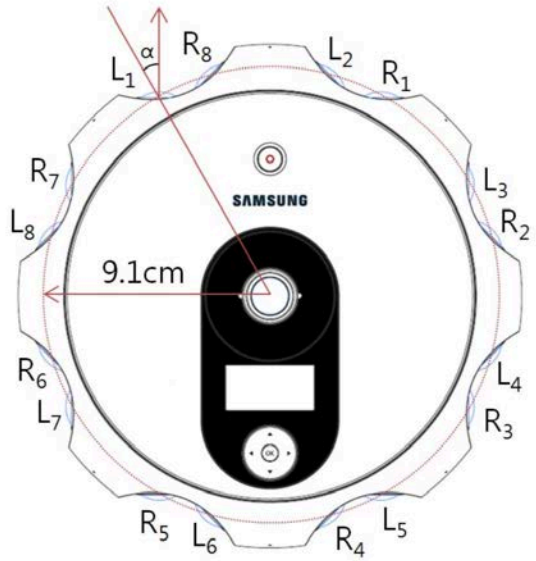

Don't compute 2D optical flow

Don't compute 2D optical flow

Rely on calibration

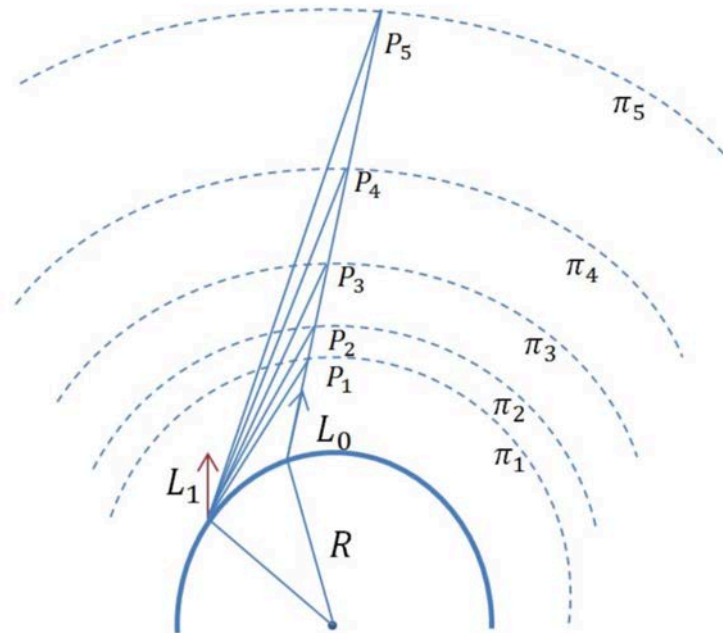
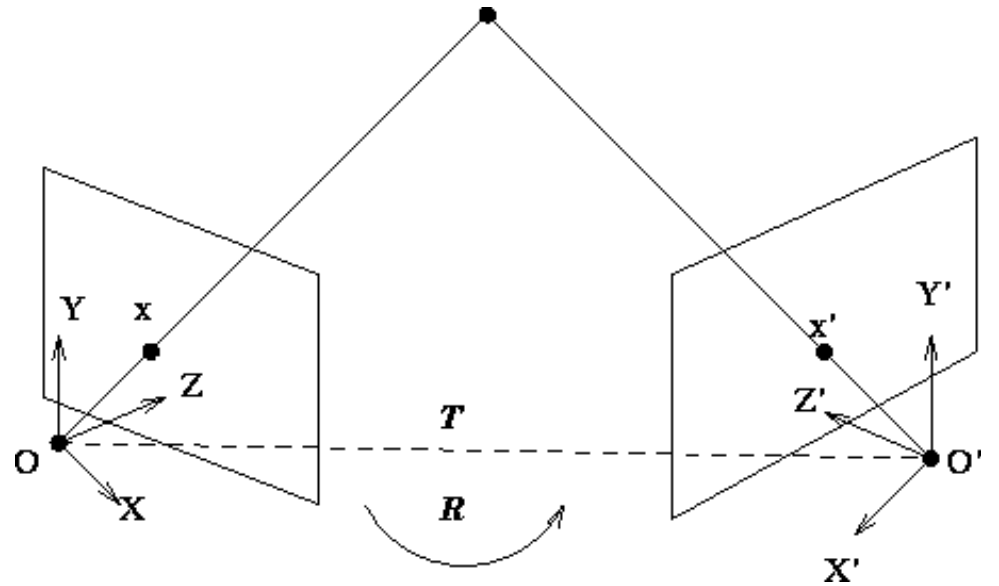
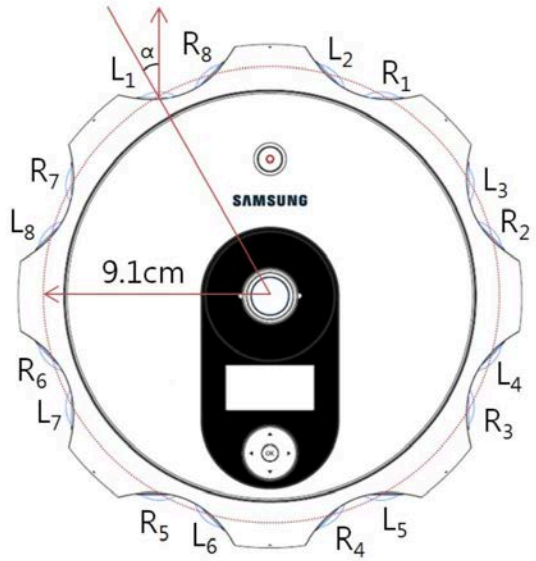

Don't compute 2D optical flow

Don't compute 2D optical flow

No guarantee on temporal consistency

Artifacts



(video courtesy of CreatorUp Youtube Channel)

Live Streaming Camera Arrays

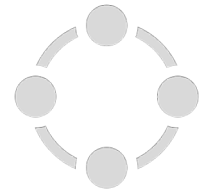

Single Shot ODS capture



Rotating ODS capture

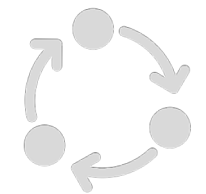

Single Shot Stereo ODS

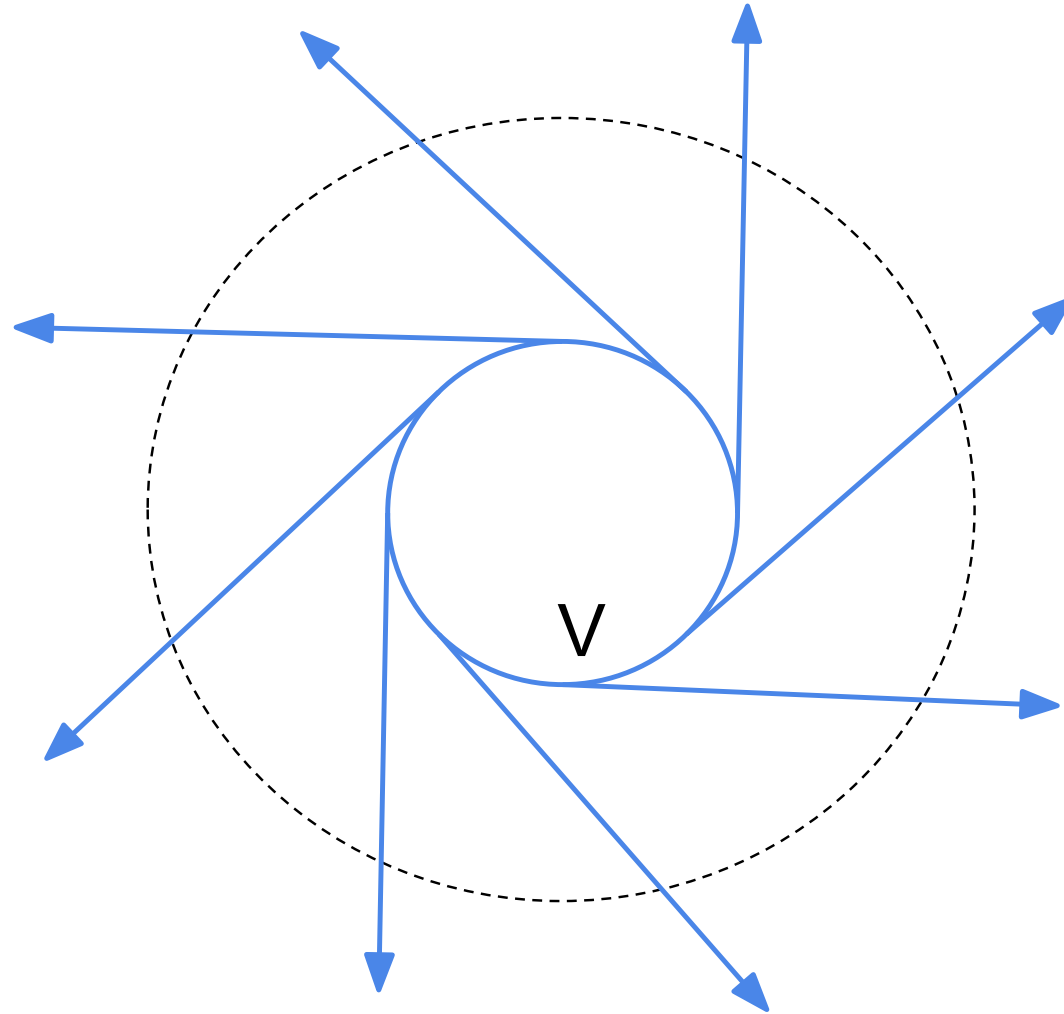

Single Shot Stereo ODS

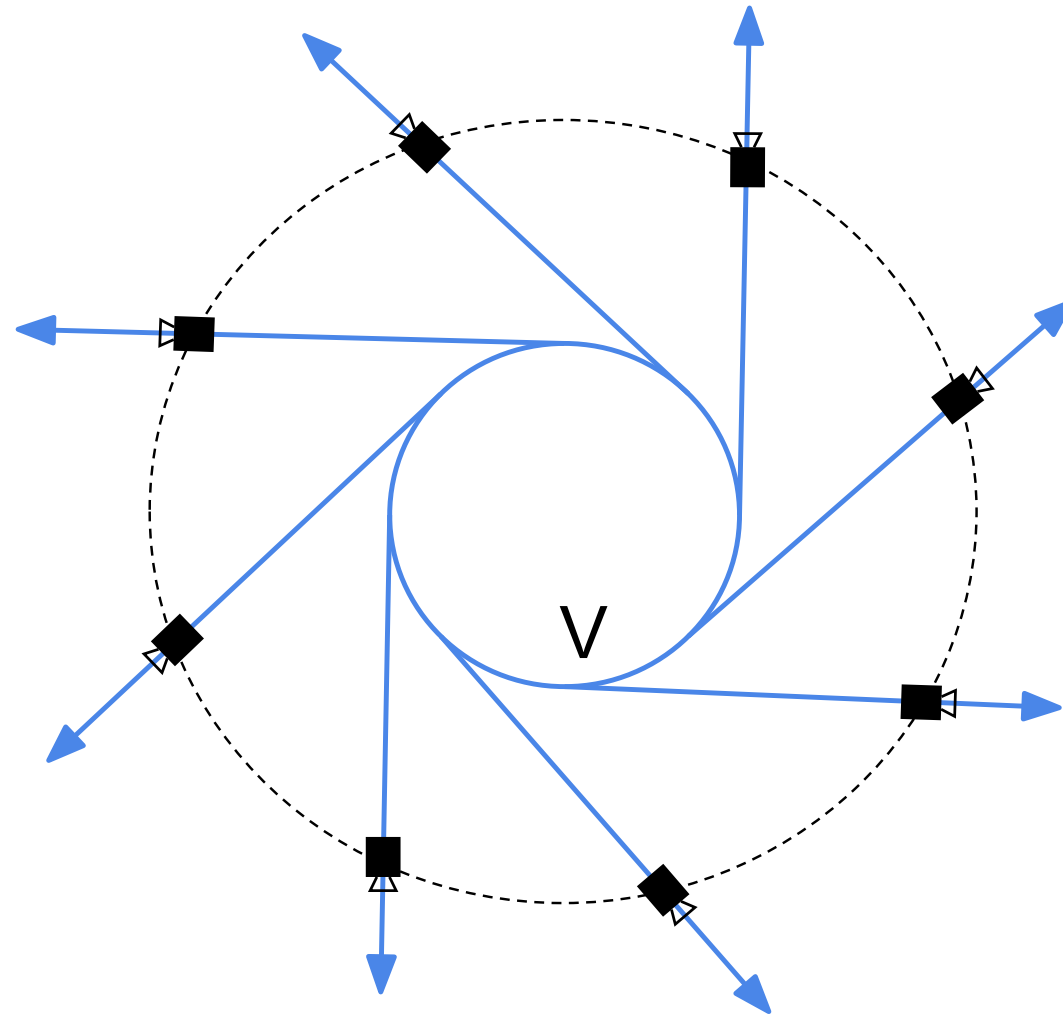

Single Shot Stereo ODS

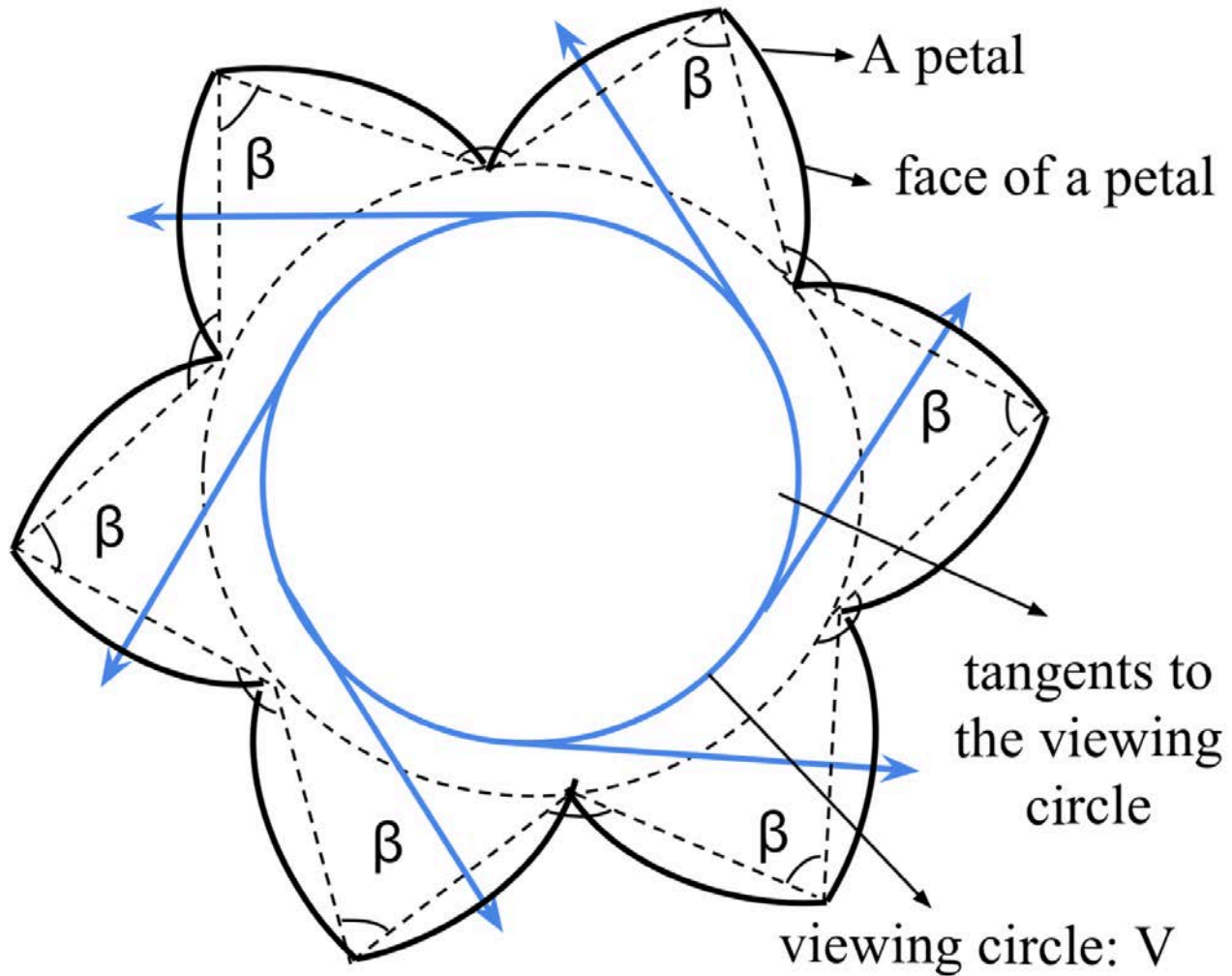

Single Shot Stereo ODS

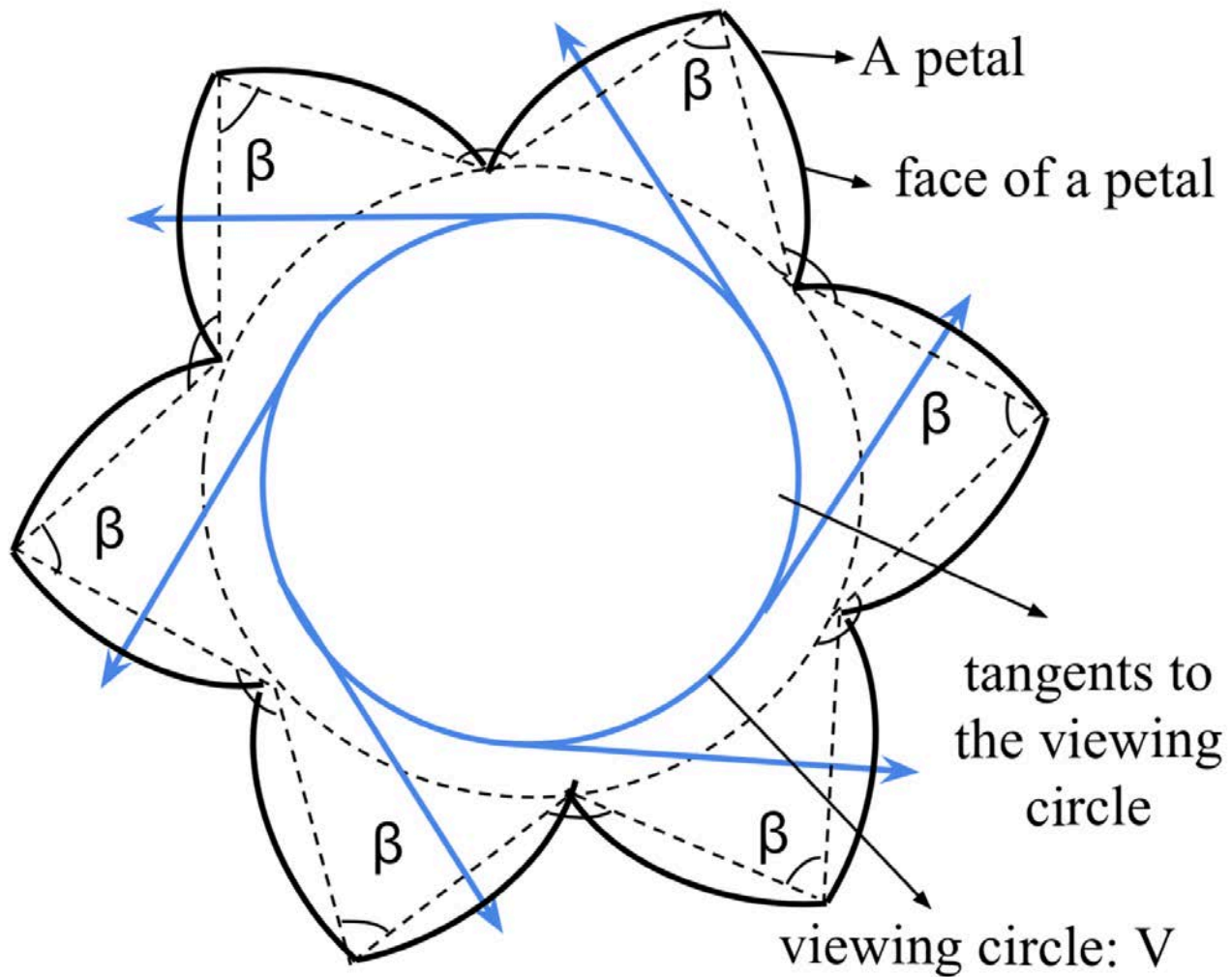

Simulated Capture



Simulated Capture

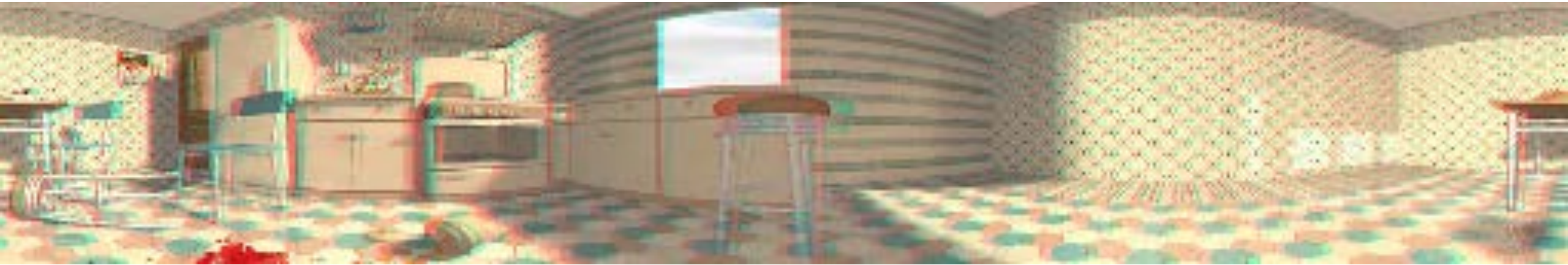

Real Capture



Other Optical Designs

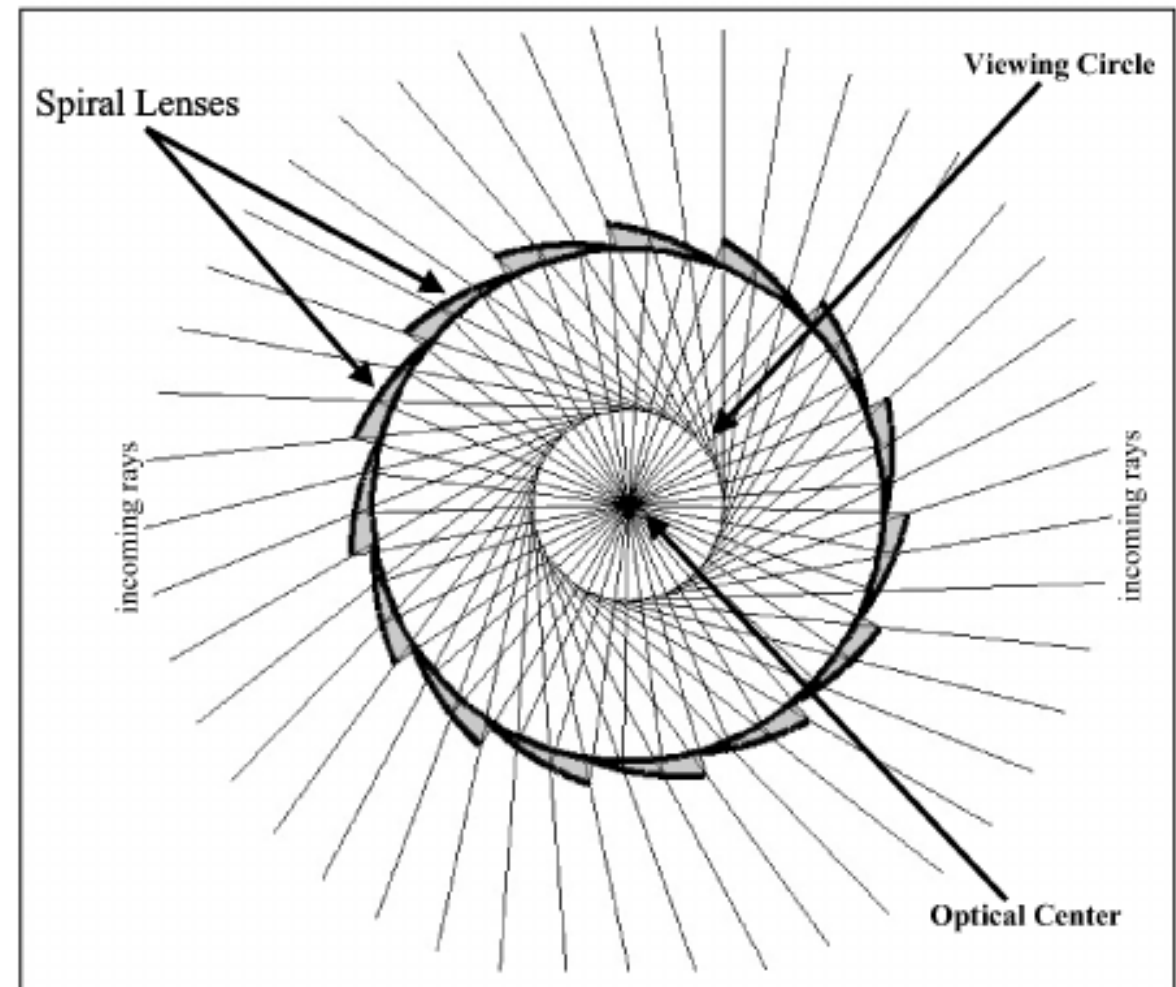
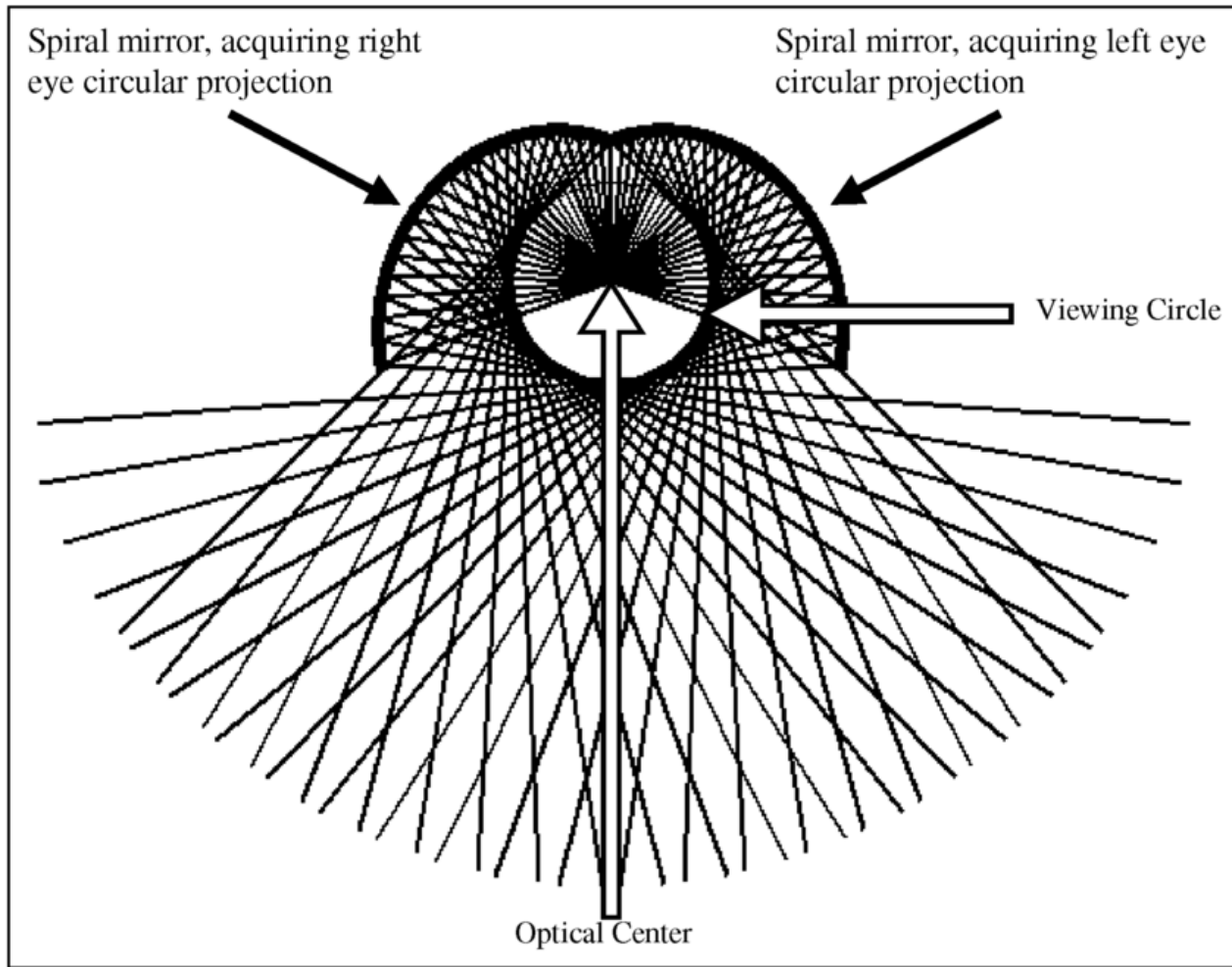

Live Streaming Camera Arrays

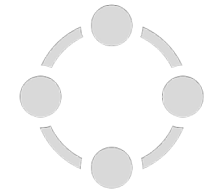

Single Shot ODS capture



Rotating ODS capture

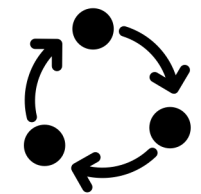

Omnidirectional Stereo (ODS)

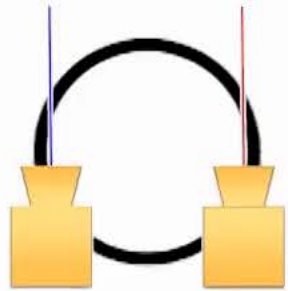

Left Eye



Right Eye



SpinVR

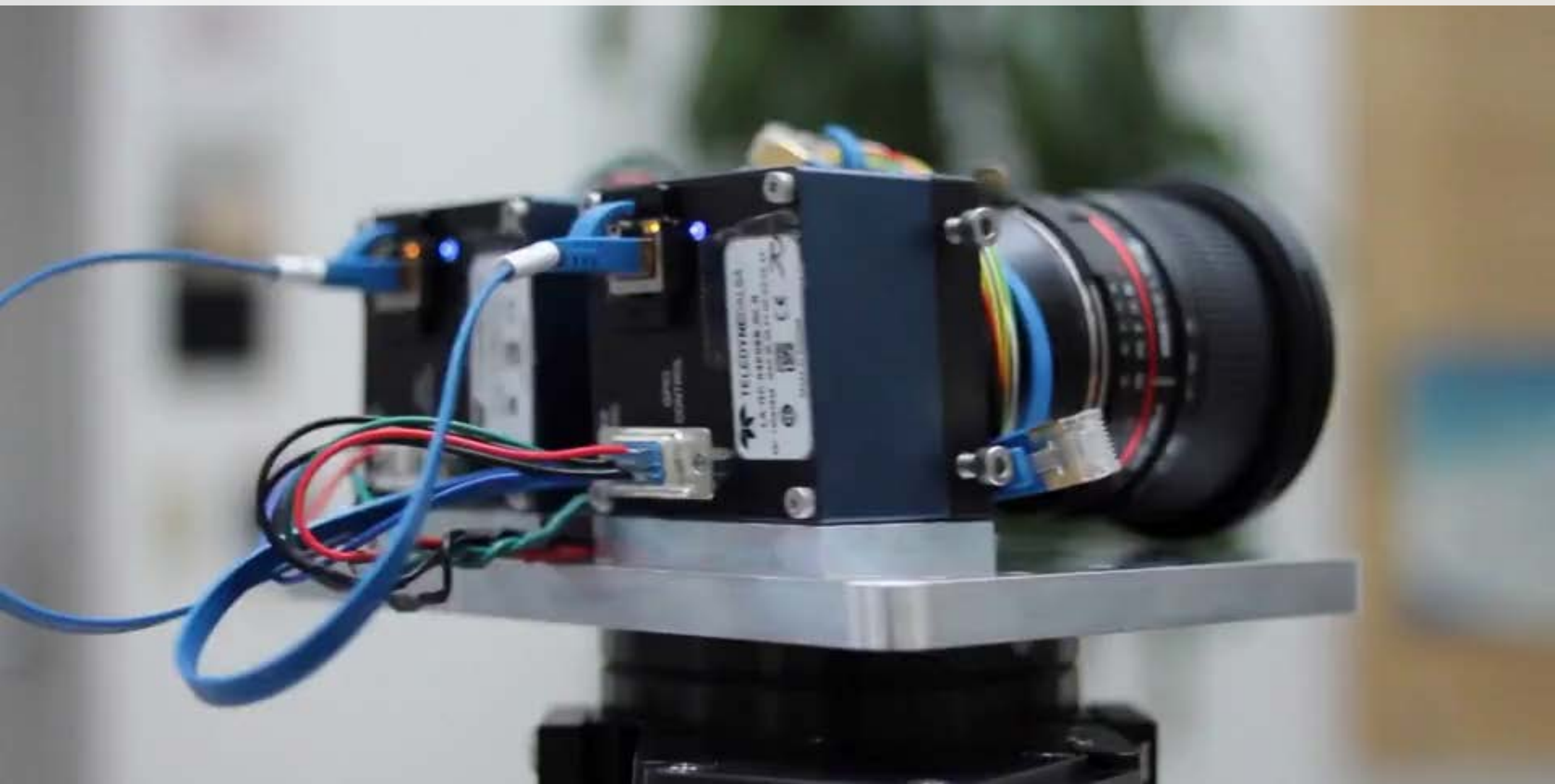

Line scan cameras

175° lenses

Rotary stage

Servo motor

Slip ring

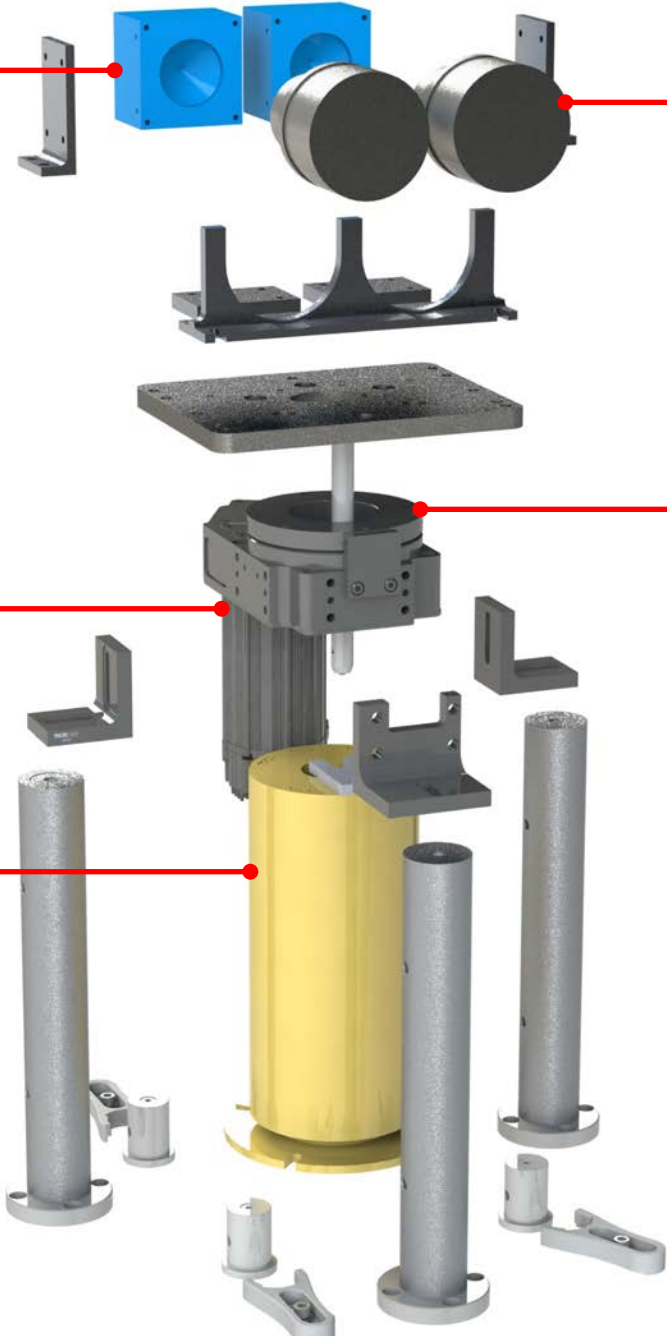

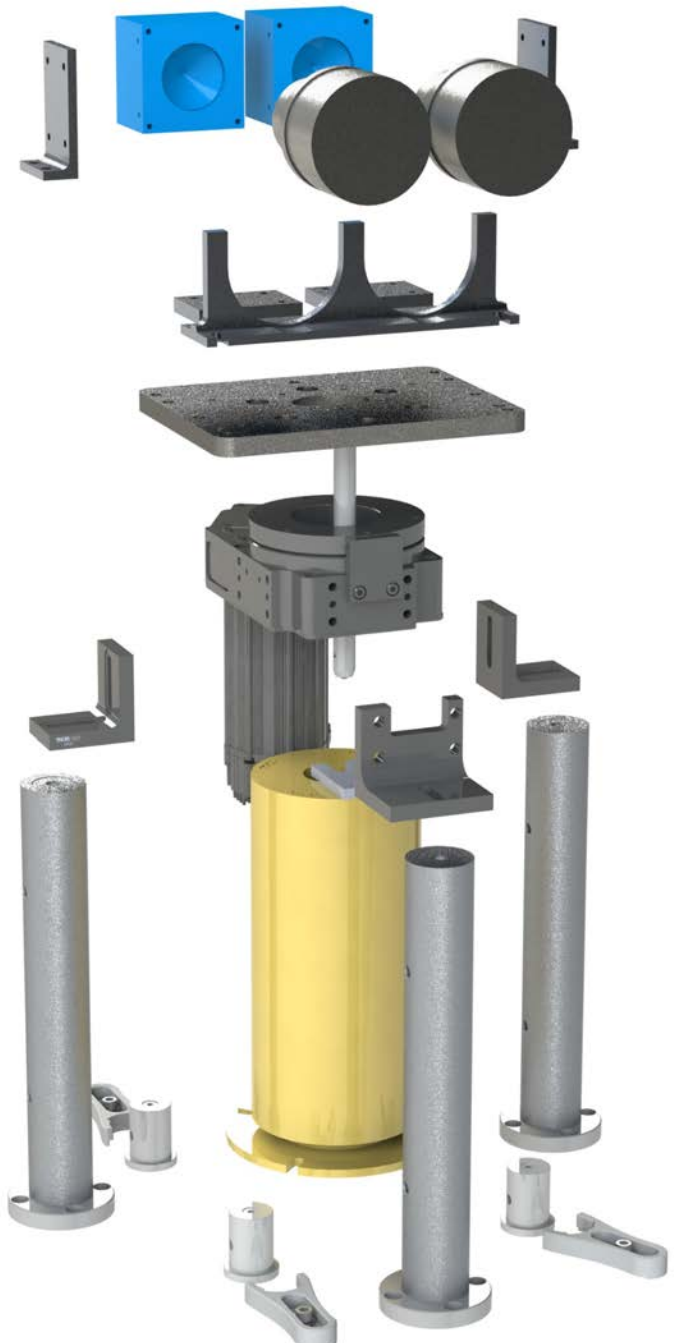

Pipeline Comparison

Minimal capture BW

Minimal compute

→ Solves artifact issues*

→ No calibration*

*Some new challenges

*New design space

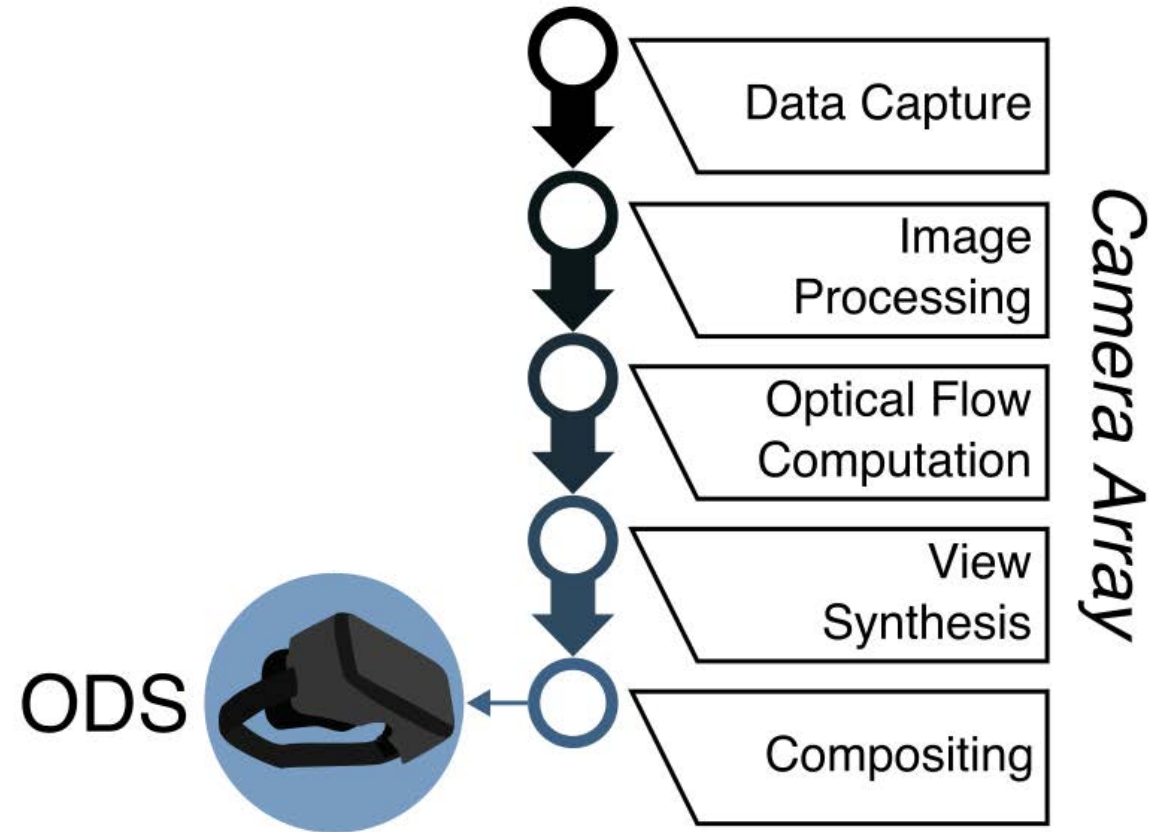

Design Trade-offs

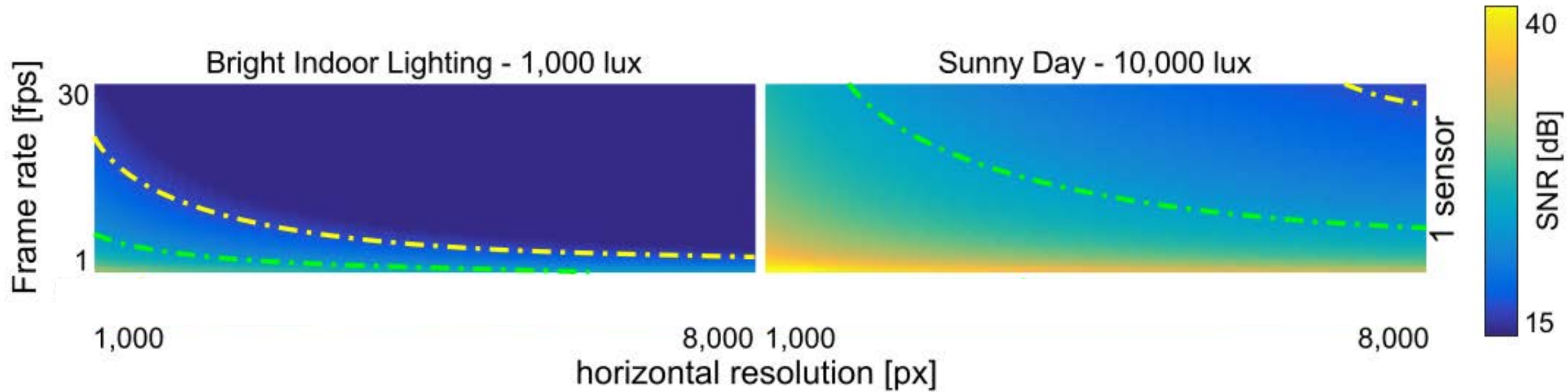

Design Trade-offs

Bright Indoor Lighting - 1,000 lux

Sunny Day - 10,000 lux

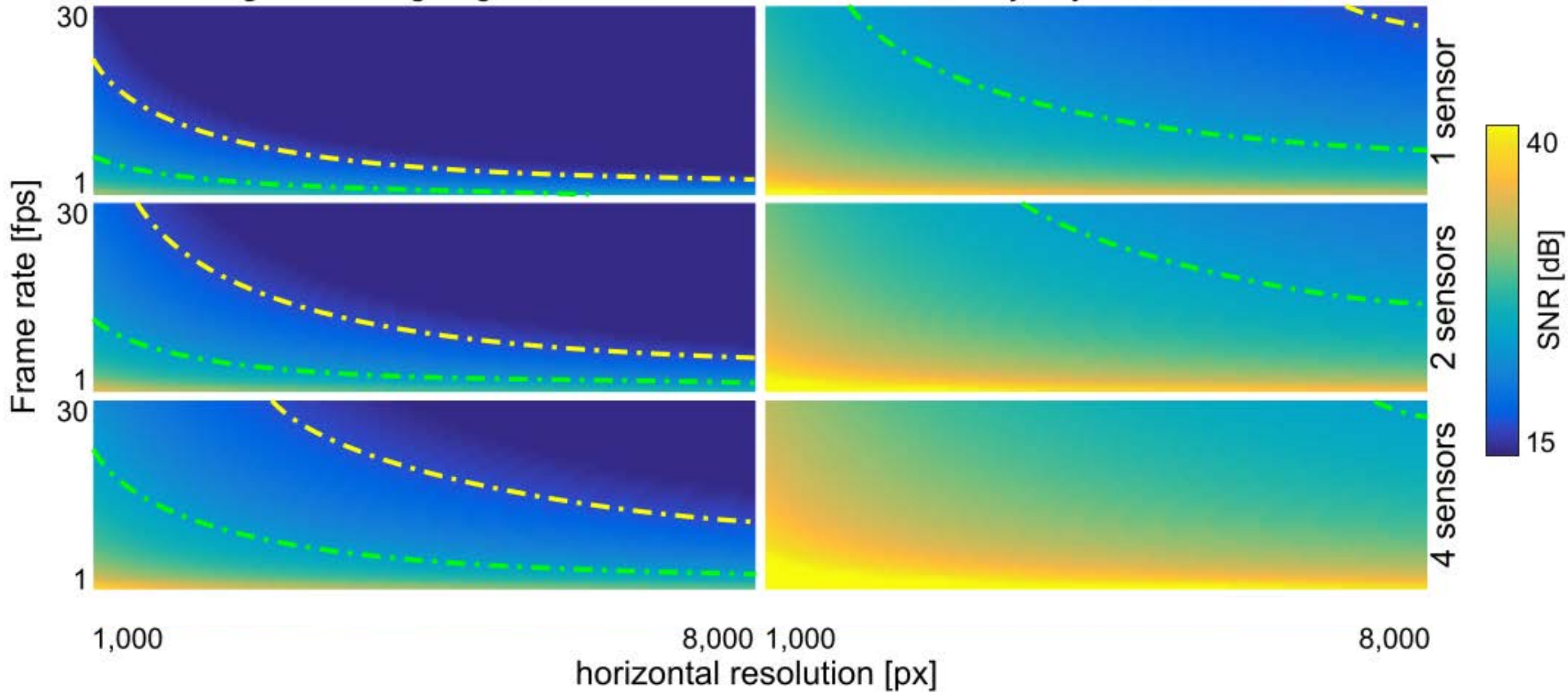



8192 x 4096 x 1/26 fps

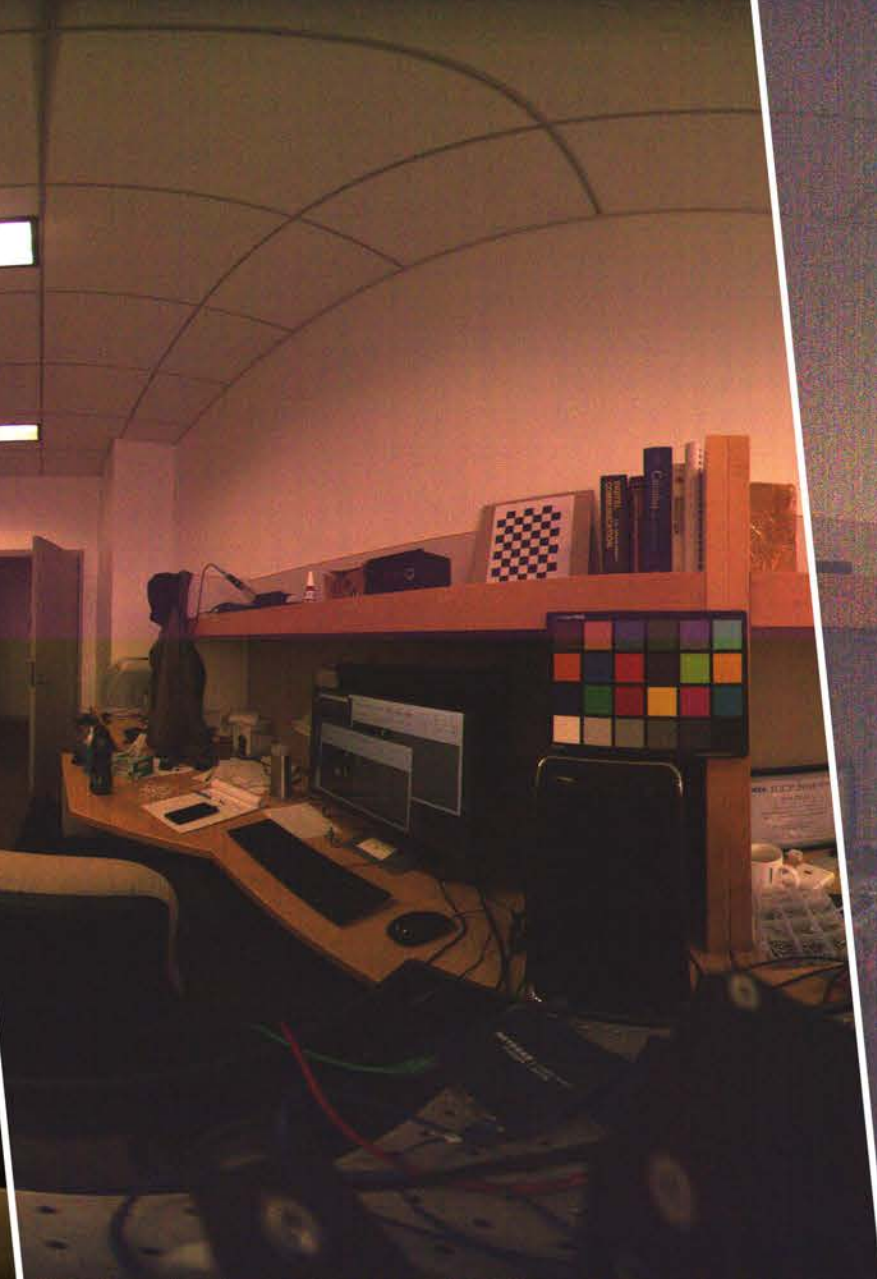

4096 x 4096 x 1.11 fps



2048 x 4096 x 16.67 fps



8192 x 4096 x 1/26 fps



4096 x 4096 x 1.11 fps

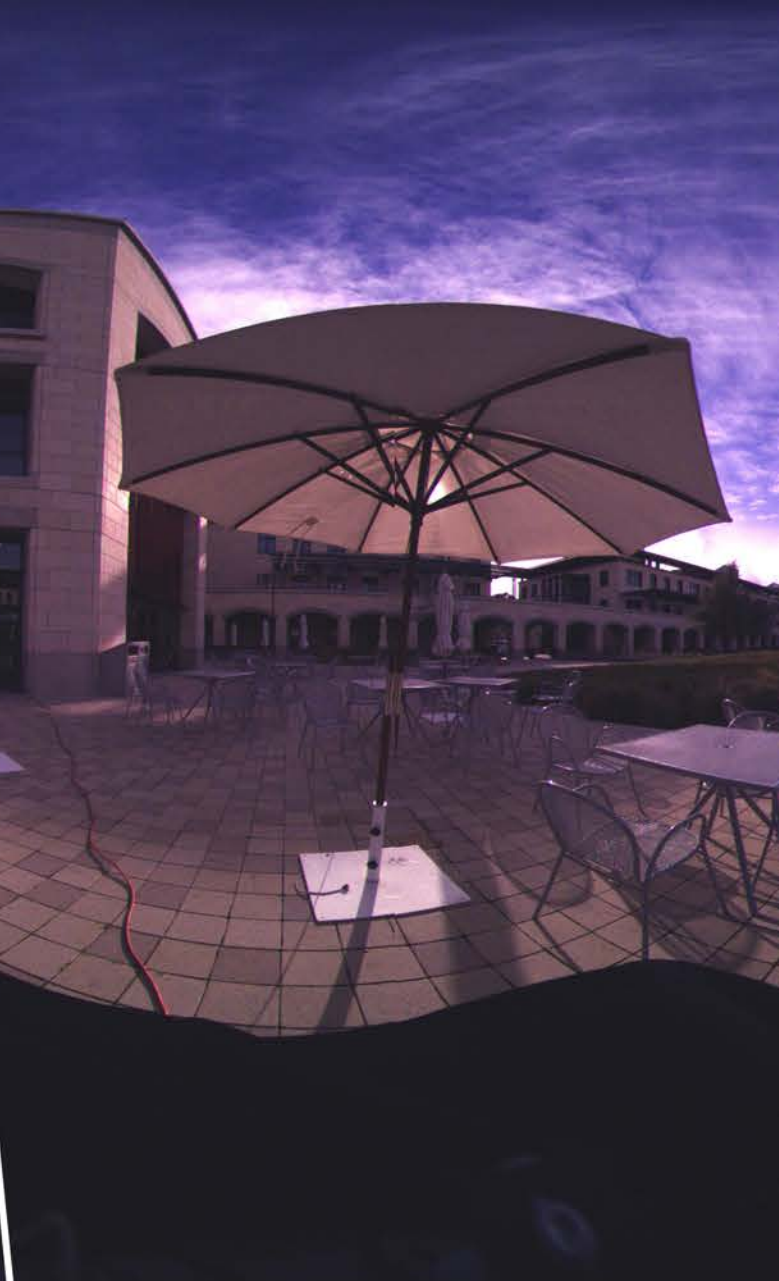

2048 x 4096 x 16.67 fps



Challenging Scenes

Reflections

Transparency

Occlusions

Fine structure

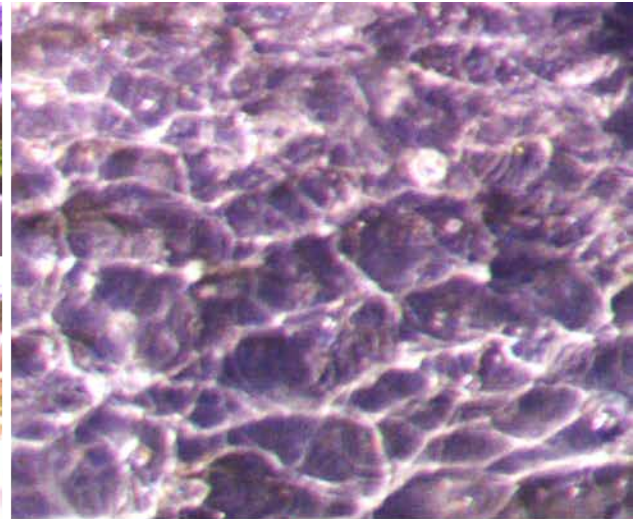

TORNADO

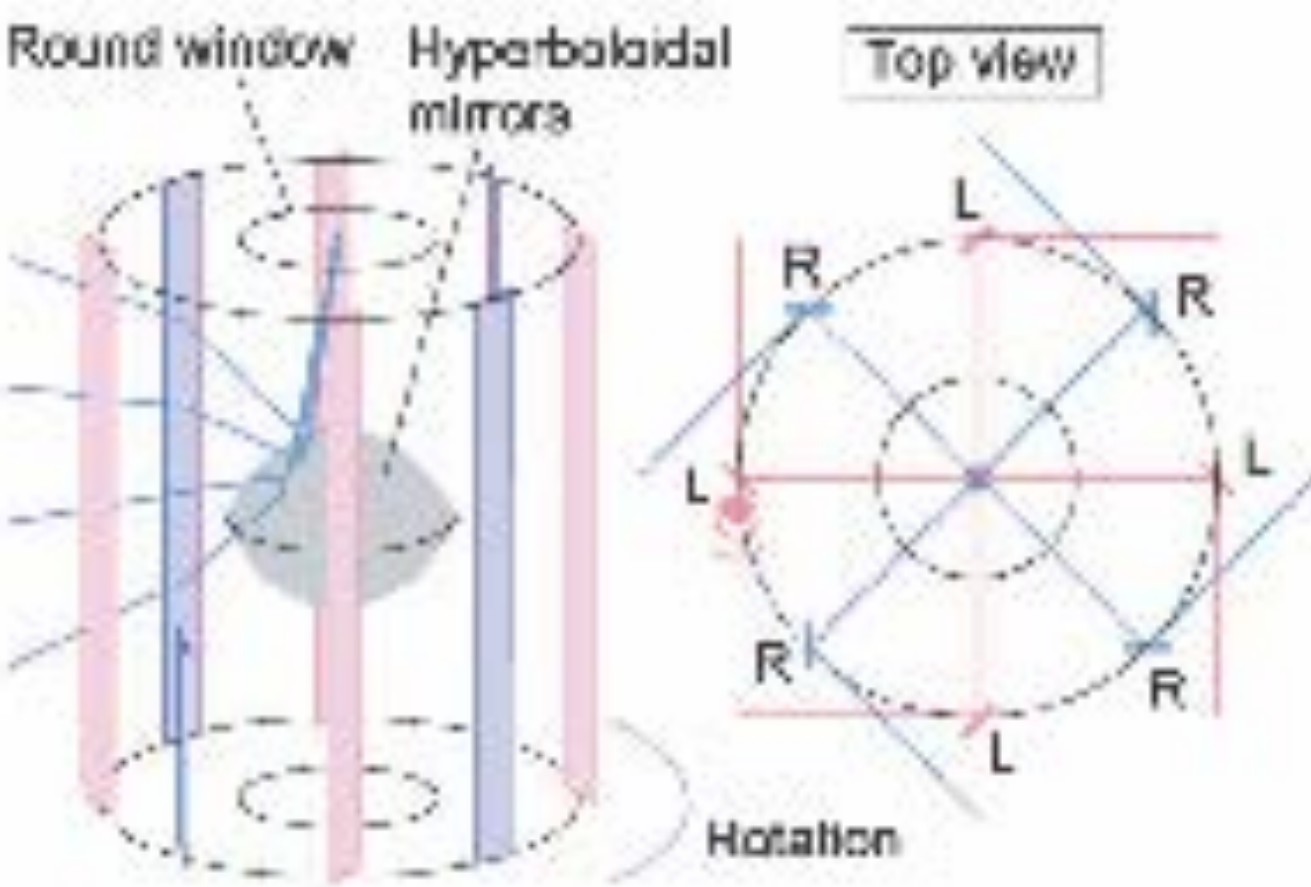

Live ODS Video (is hard)

Robert Konrad

TORNADO

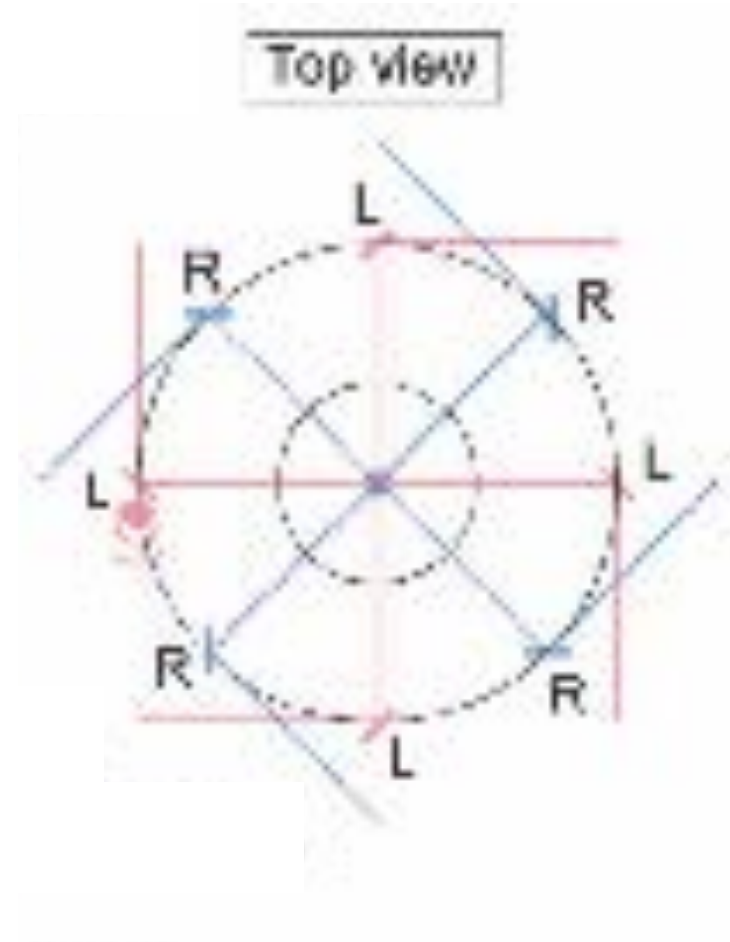

TORNADO

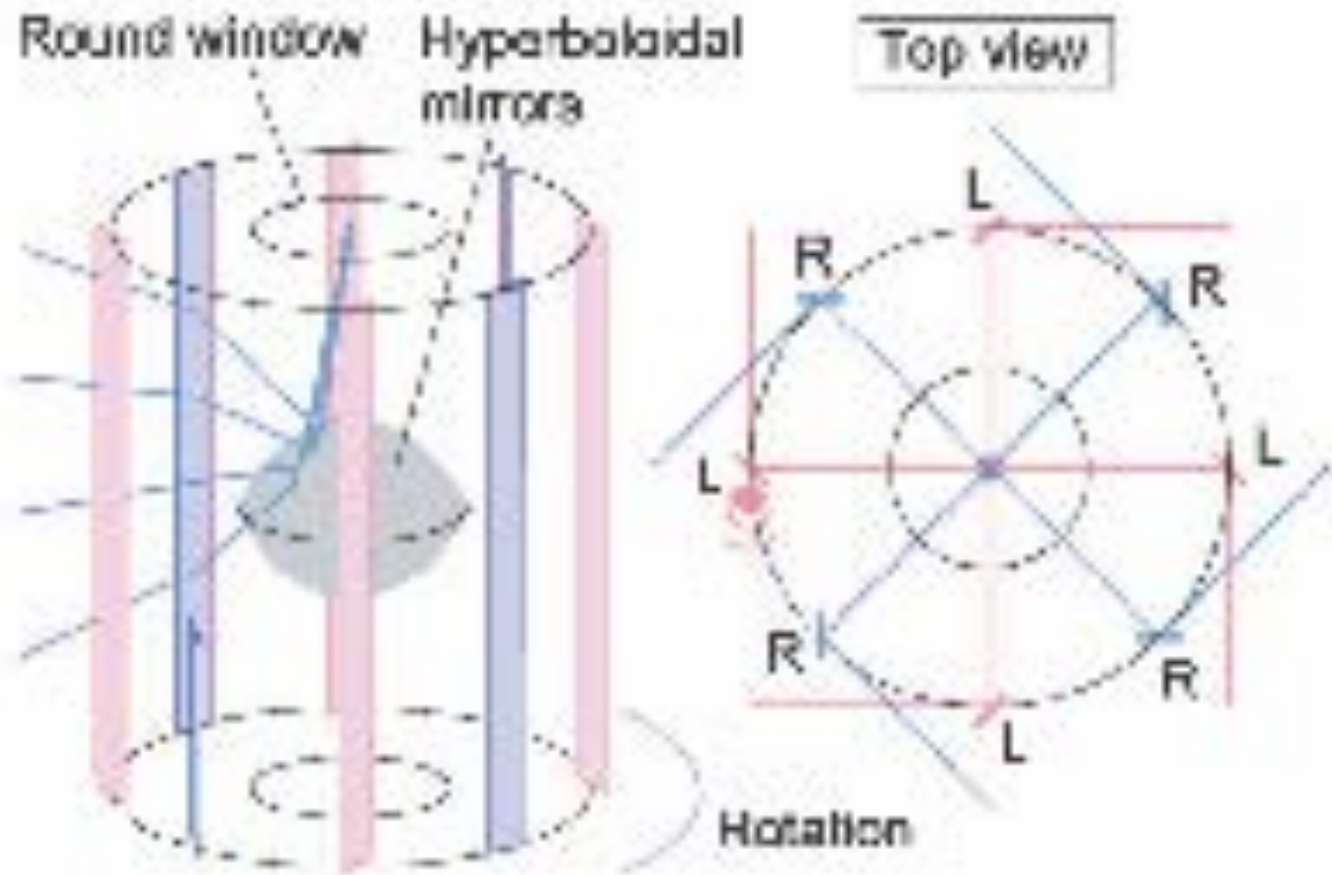

TORNADO

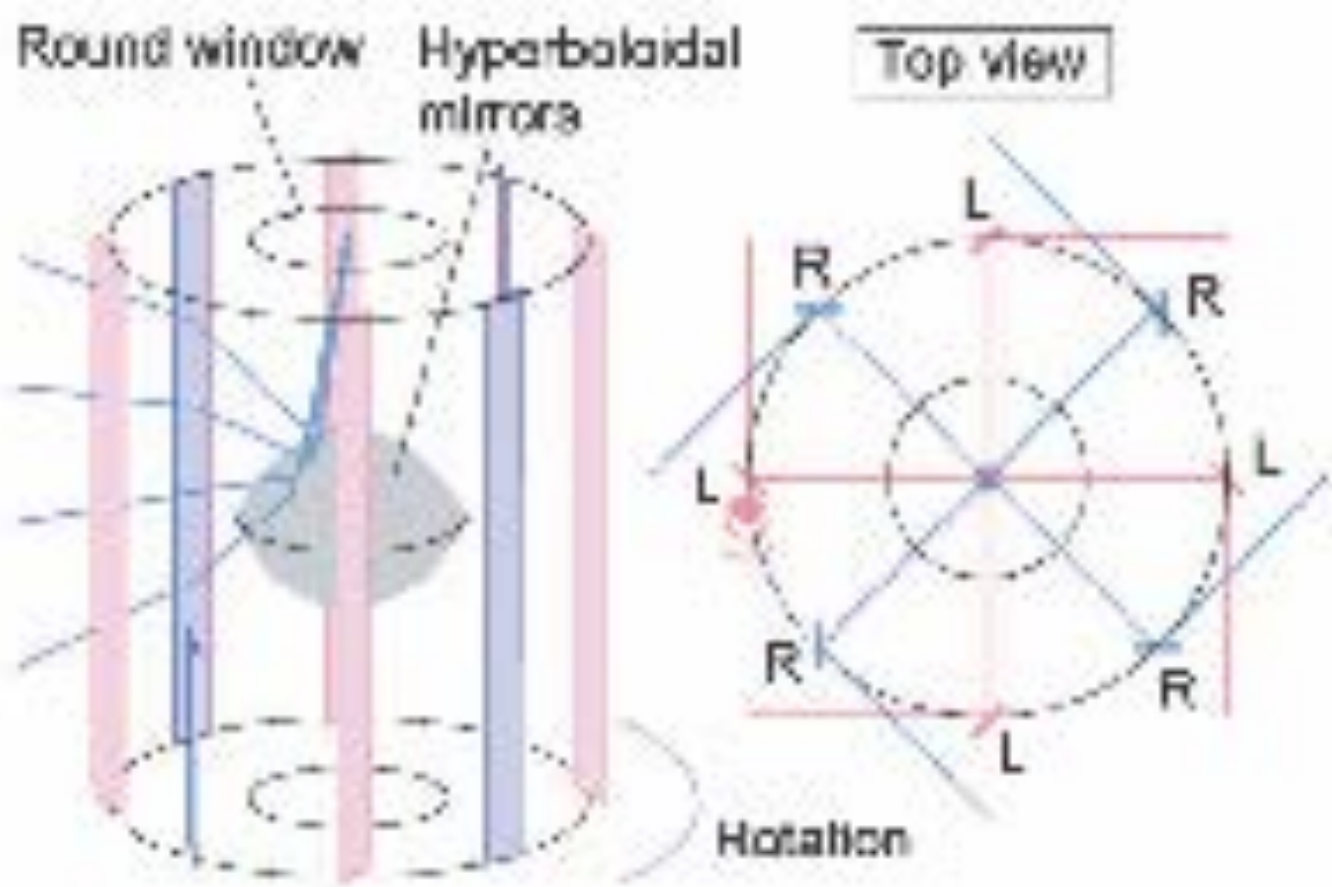

Prism Sheet Working Principle

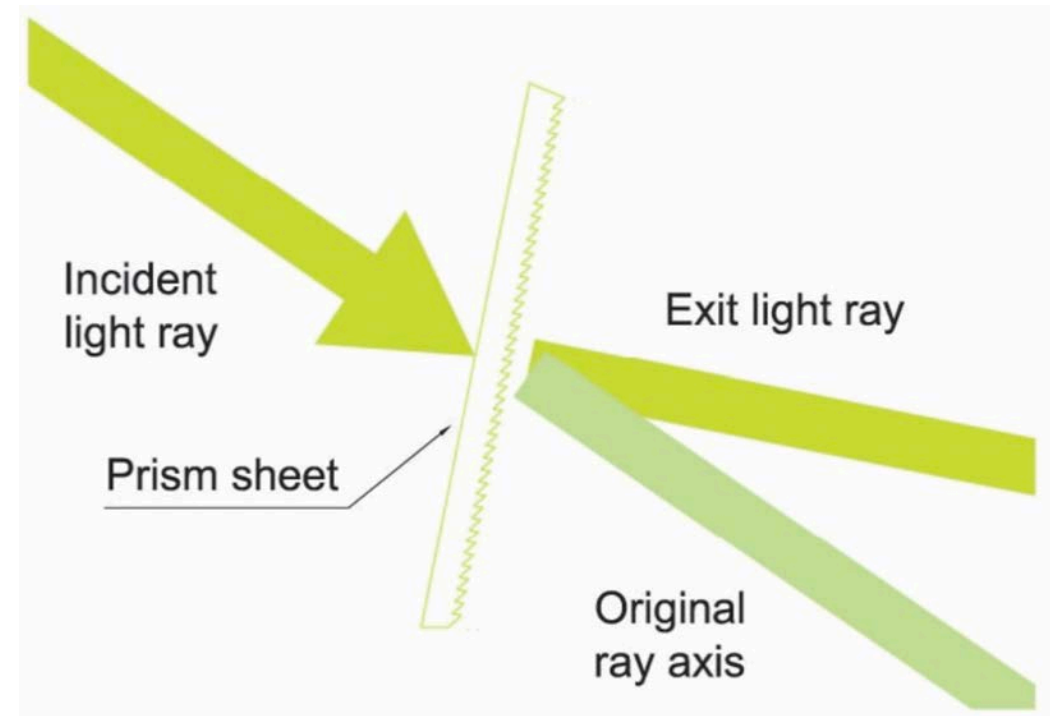

TORNADO

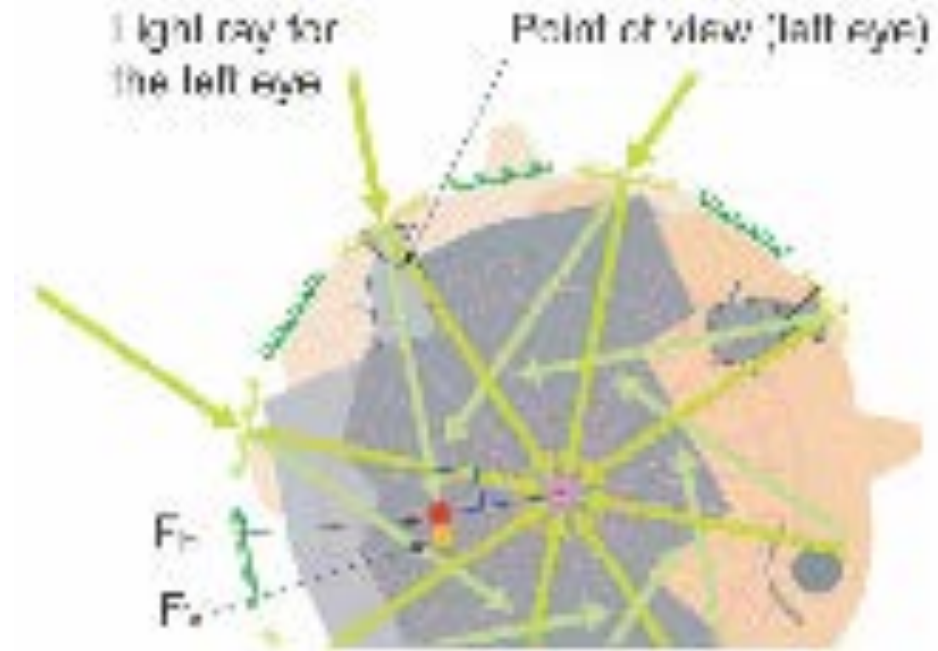

TORNADO

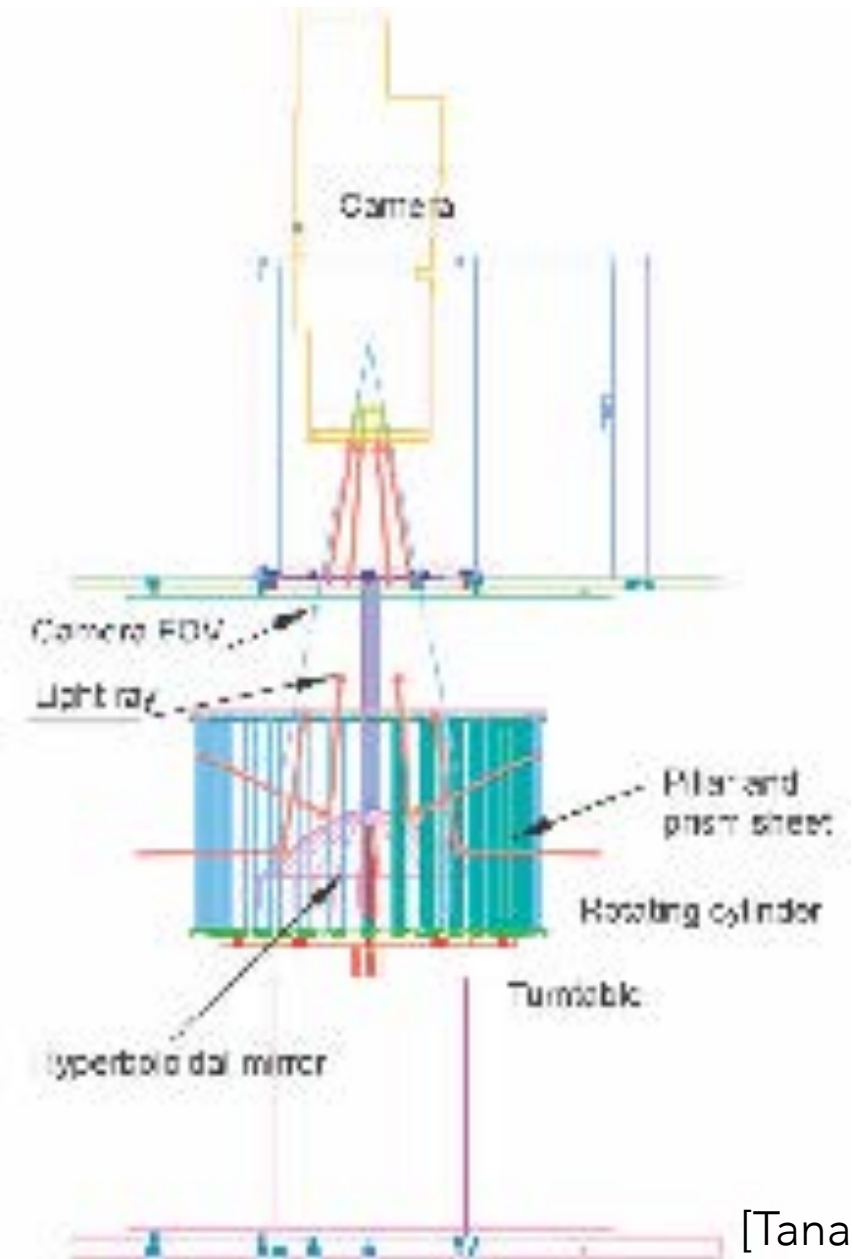
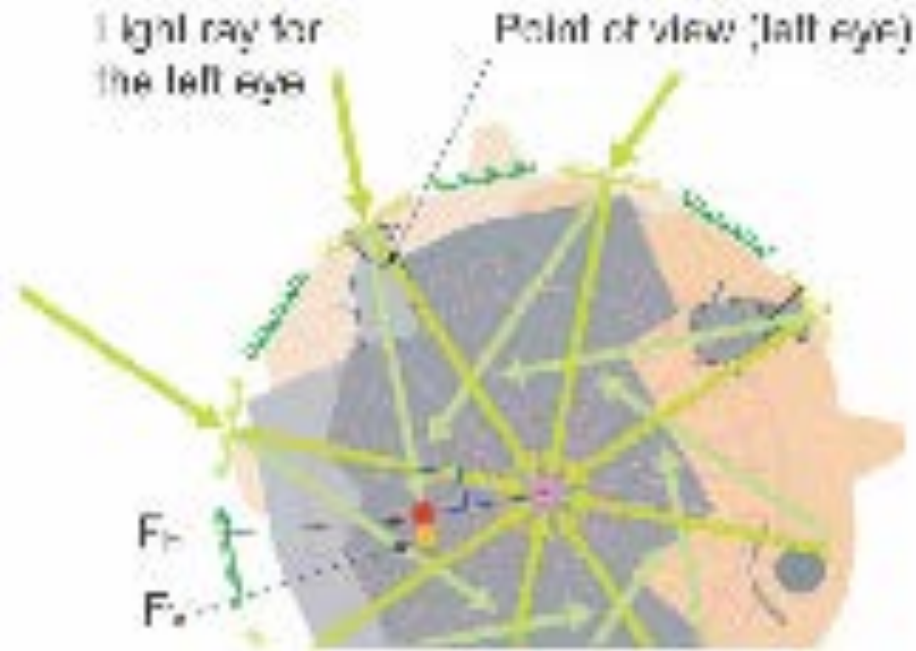

TORNADO



TORNADO

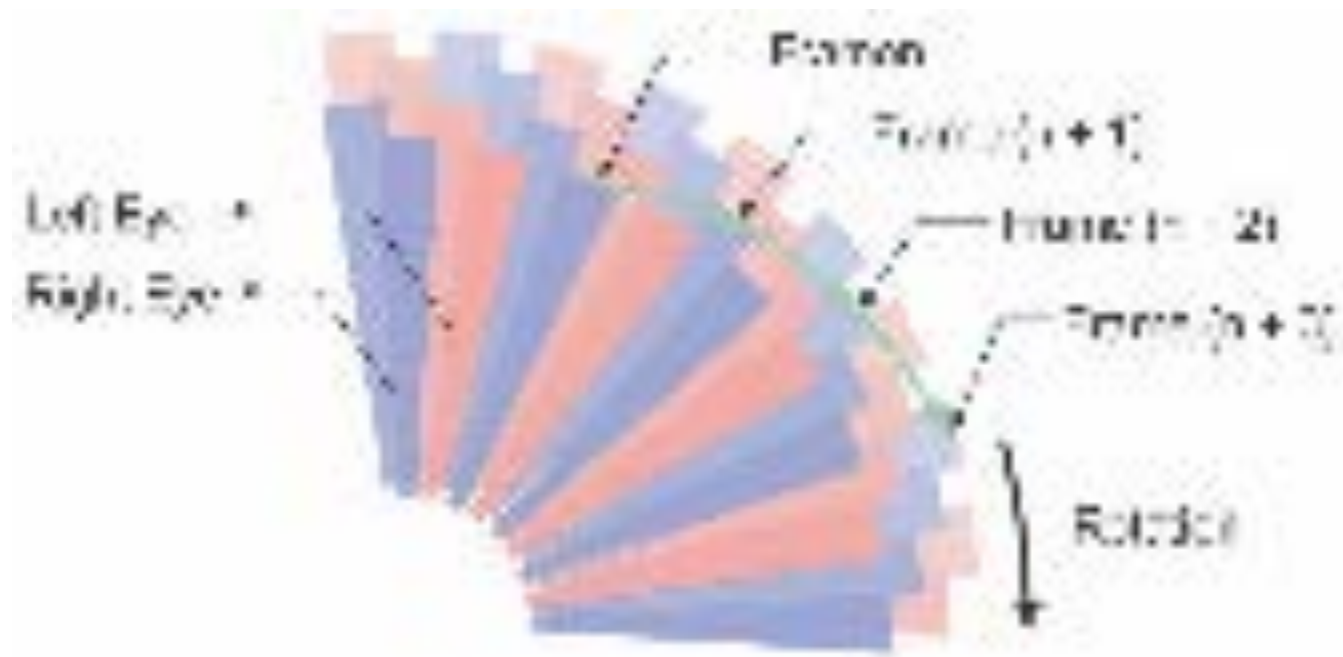

TORNADO

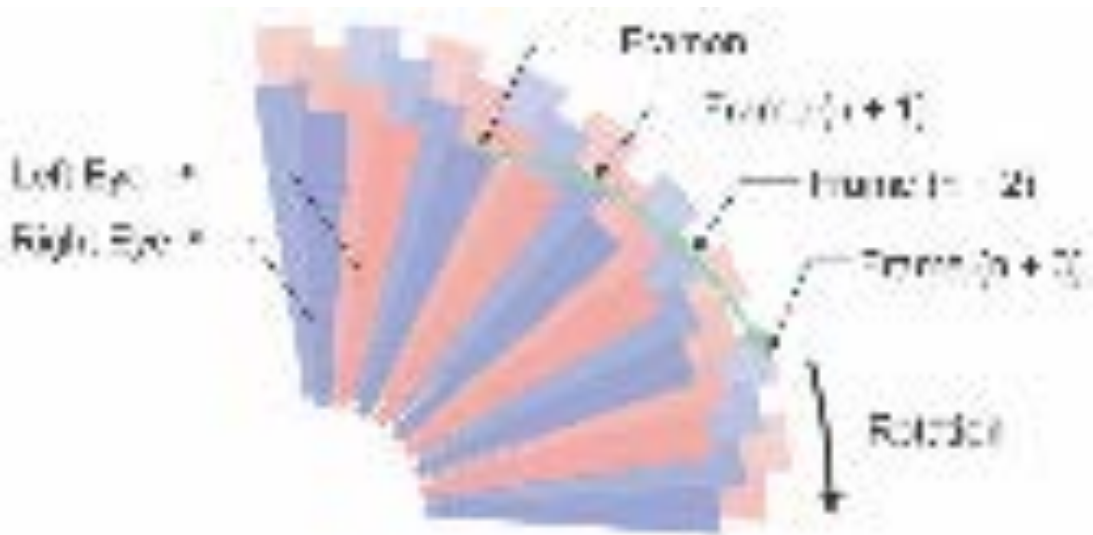

TORNADO

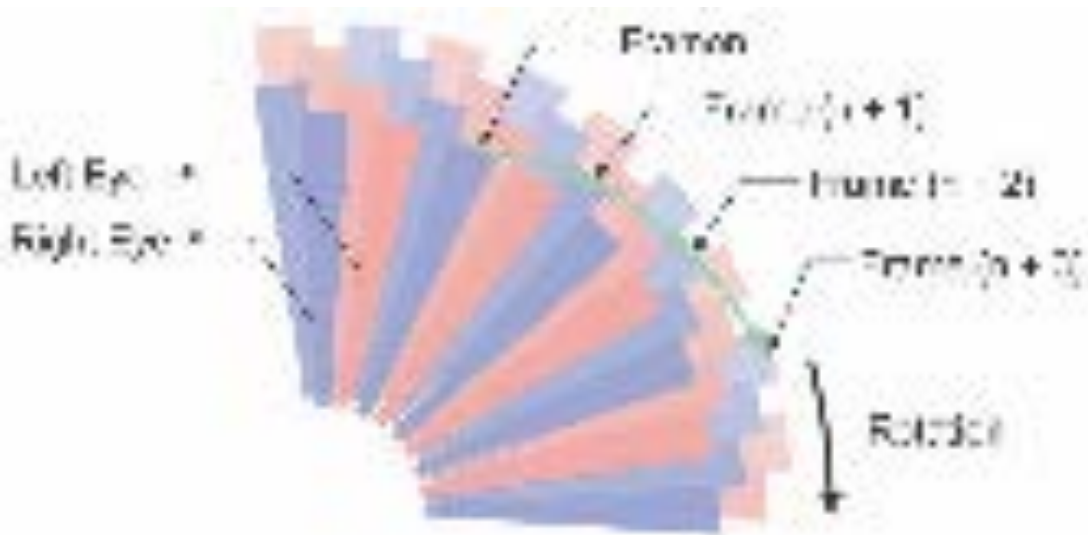

TORNADO

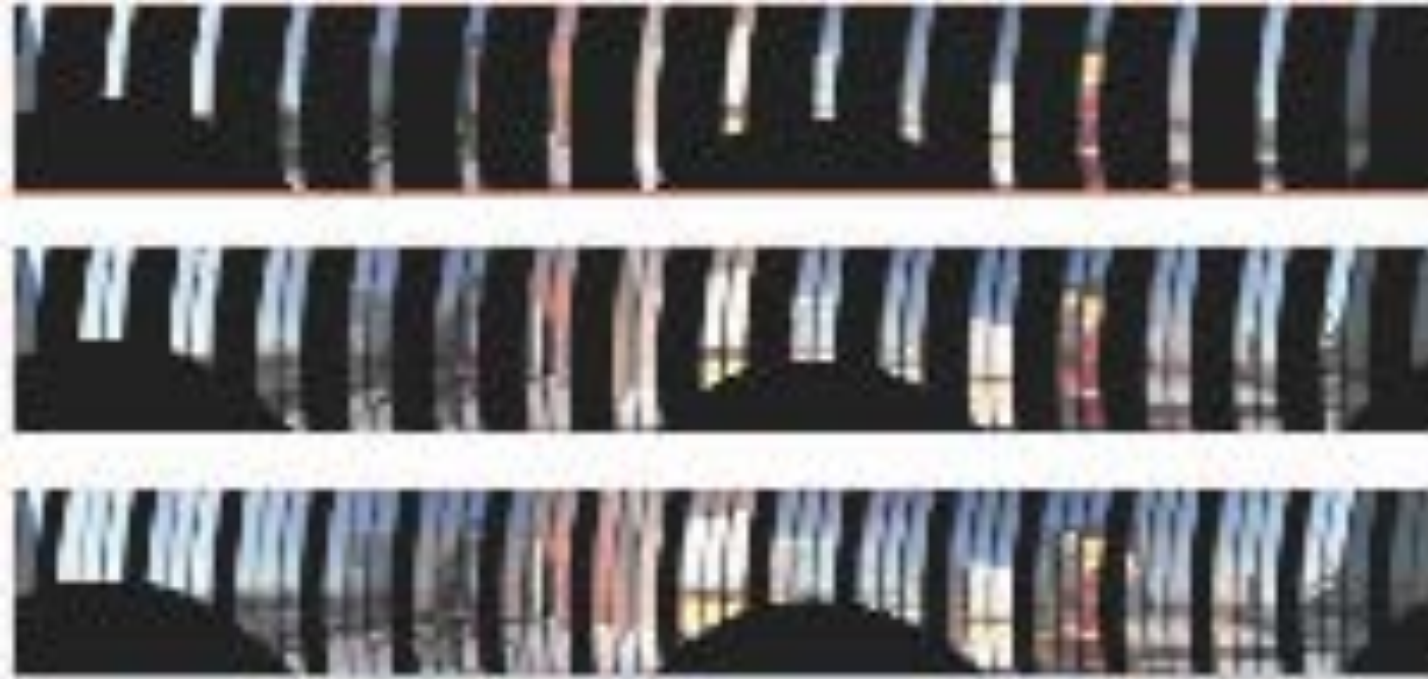
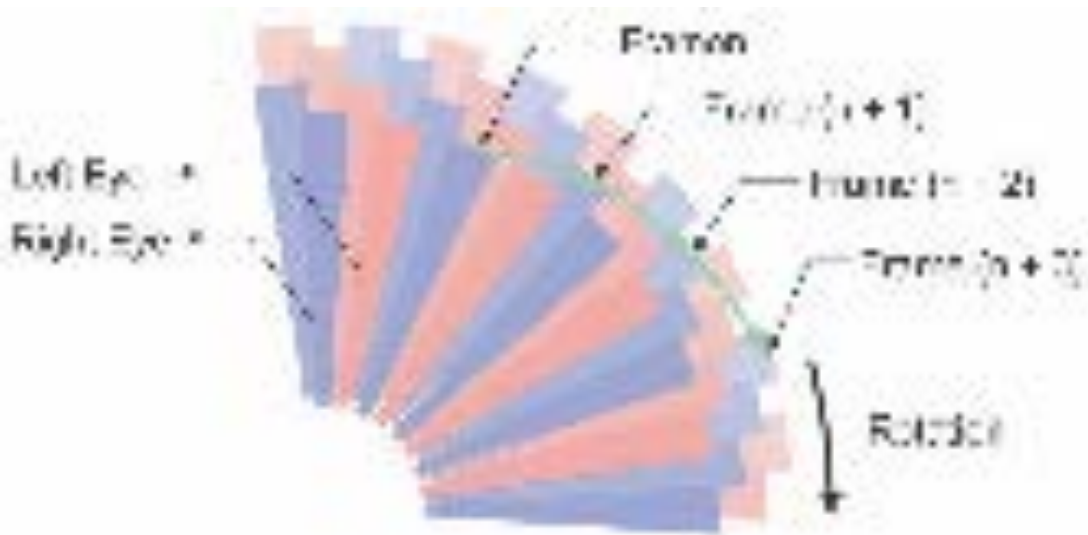

TORNADO

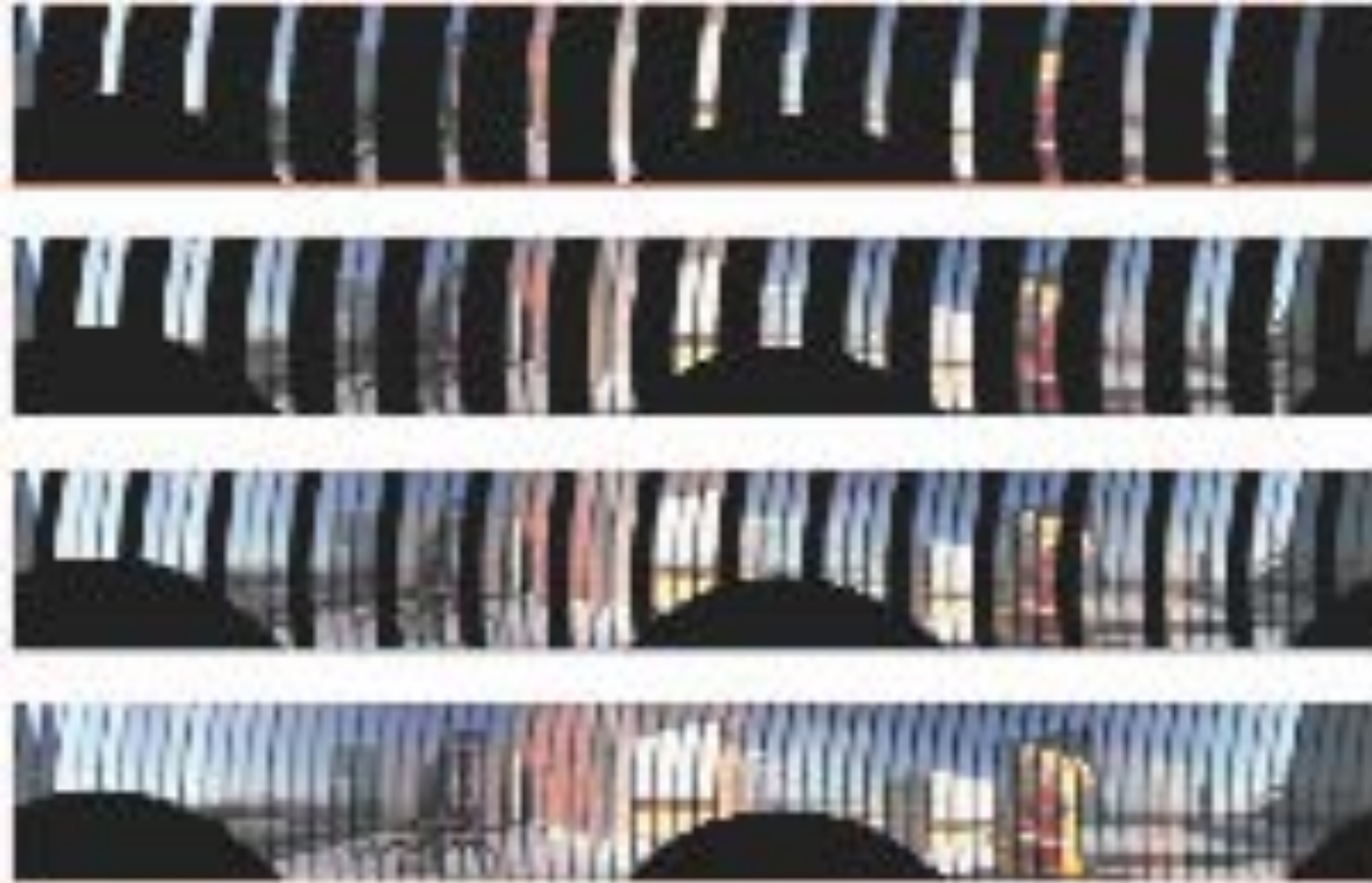
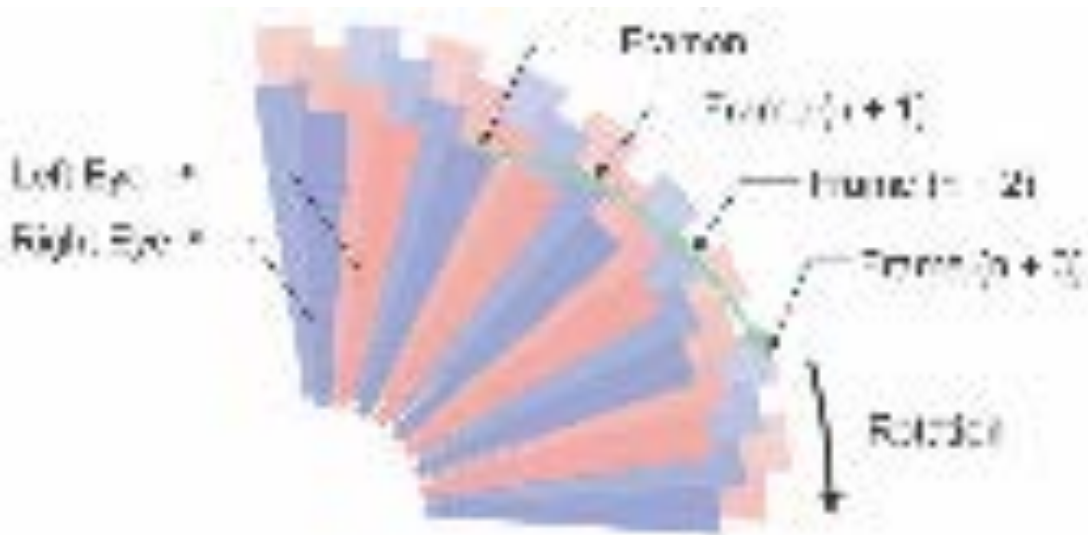

Seamless Rendering

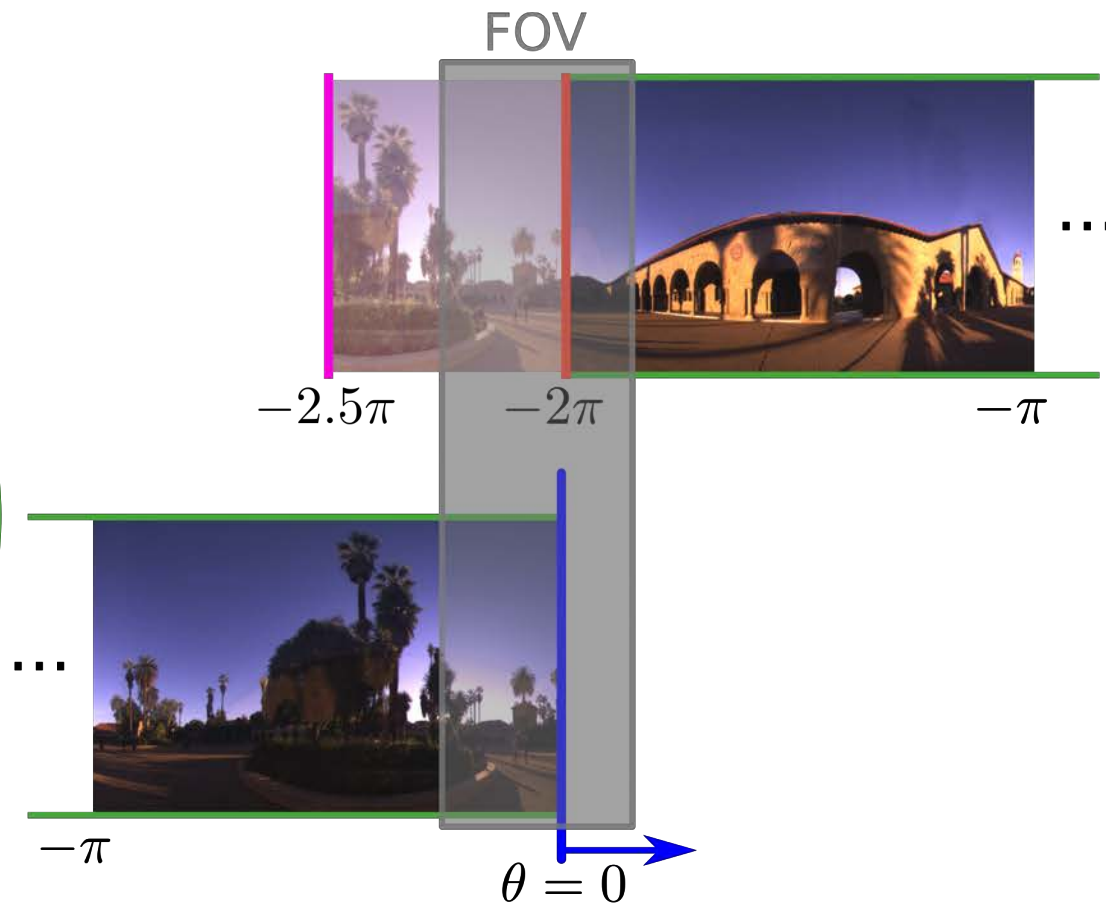
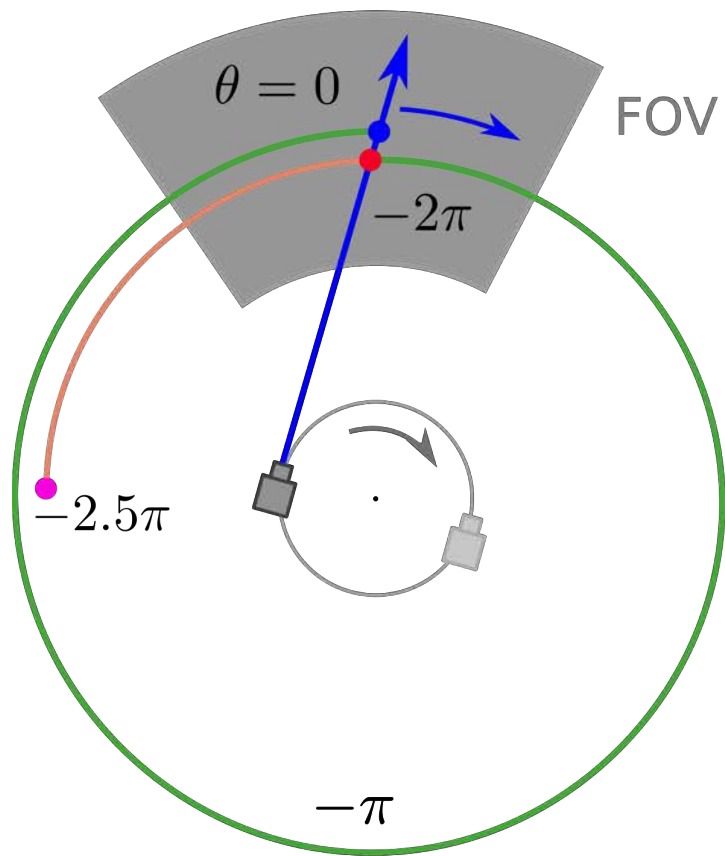

Warping at the Poles

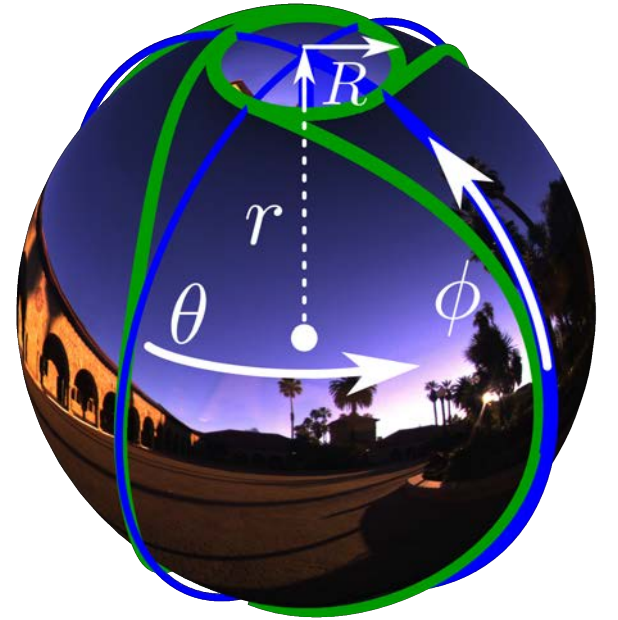
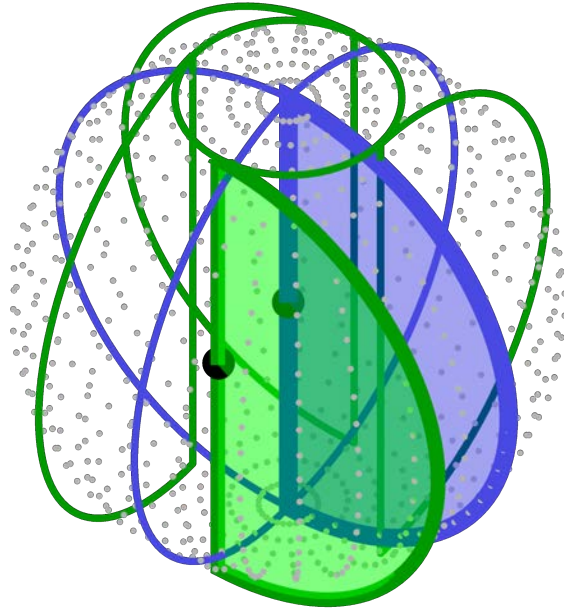
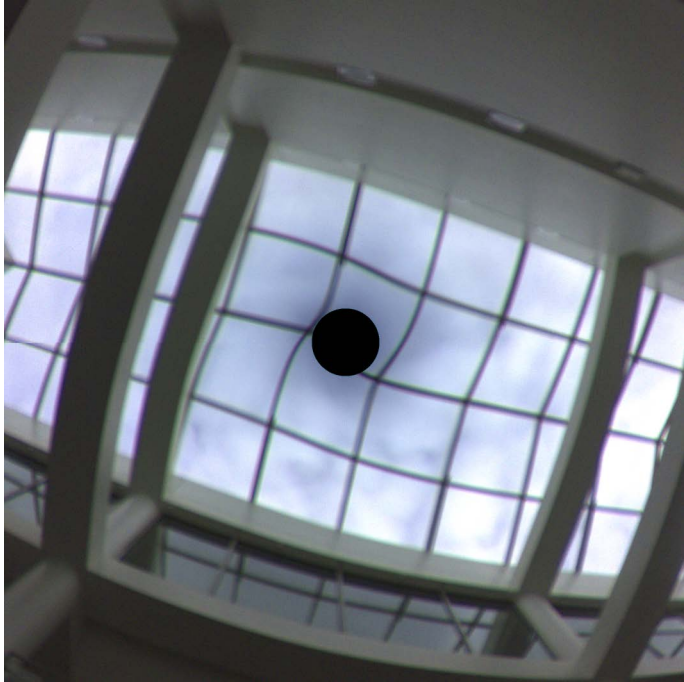

$$\Delta\theta = \tan^{-1} \left(\frac{R/r}{\cos \phi} \right)$$

$$\Delta\phi = \tan^{-1} \left(\frac{\sin \phi}{\sqrt{(R/r)^2 + \cos^2 \phi}} \right) - \phi$$

Warping at the Poles

